

Honeywell

INSTALLATION MANUAL

BENDIX/KING[®]

KCS 55/55A

***PICTORIAL NAVIGATION
SYSTEM***

***MANUAL NUMBER 006-00111-0011
REVISION 11 April 2007***

WARNING

Prior to the export of this document, review for export license requirement is needed.

COPYRIGHT NOTICE

©1997-2002, 2007 Honeywell International Inc.

Reproduction of this publication or any portion thereof by any means without the express written permission of Honeywell is prohibited. For further information contact the manager, Technical Publications, Honeywell, One Technology Center, 23500 West 105th Street Olathe KS 66061 telephone: (913) 712-0400.

Honeywell Materials License Agreement

The documents and information contained herein ("the Materials") are the proprietary data of Honeywell International Inc. and Honeywell Intellectual Properties Inc. (collectively "Honeywell"). These Materials are provided for the exclusive use of Honeywell Service Centers; Honeywell-authorized repair facilities; operators of Honeywell aerospace products subject to an applicable product support agreement, their wholly owned-subsiidiaries or a formally designated third party service provider thereunder; and direct recipients of Materials from Honeywell's Aerospace Technical Publication Distribution. The terms and conditions of this License Agreement govern your use of these Materials, except to the extent that any terms and conditions of another applicable agreement with Honeywell regarding the operation, maintenance, or repair of Honeywell aerospace products conflict with the terms and conditions of this License Agreement, in which case the terms and conditions of the other agreement will govern. However, this License Agreement will govern in the event of a conflict between its terms and conditions and those of a purchase order or acknowledgement.

1. License Grant - If you are a party to an applicable product support agreement, a Honeywell Service Center agreement, or an authorized repair facility agreement, Honeywell hereby grants you a limited, non-exclusive license to use these Materials to operate, maintain, or repair Honeywell aerospace products only in accordance with that agreement.

If you are a direct recipient of these Materials from Honeywell's Aerospace Technical Publication Distribution and are not a party to an agreement related to the operation, maintenance or repair of Honeywell aerospace products, Honeywell hereby grants you a limited, non-exclusive license to use these Materials to maintain or repair the subject Honeywell aerospace products only at the facility to which these Materials have been shipped ("the Licensed Facility"). Transfer of the Materials to another facility owned by you is permitted only if the original Licensed Facility retains no copies of the Materials and you provide prior written notice to Honeywell.

2. Rights In Materials - Honeywell retains all rights in these Materials and in any copies thereof that are not expressly granted to you, including all rights in patents, copyrights, trademarks, and trade secrets. No license to use any Honeywell trademarks or patents is granted under this License Agreement.

3. Confidentiality - You acknowledge that these Materials contain information that is confidential and proprietary to Honeywell. You agree to take all reasonable efforts to maintain the confidentiality of these Materials.

4. Assignment And Transfer - This License Agreement may be assigned to a formally designated service designee to the extent allowed under an applicable product support agreement or transferred to a subsequent owner or operator of an aircraft containing the subject Honeywell aerospace products. However, the recipient of any such assignment or transfer must assume all of your obligations under this License Agreement. No assignment or transfer shall relieve any party of any obligation that such party then has hereunder.

5. Copies of Materials - Unless you have the express written permission of Honeywell, you may not make or permit making of copies of the Materials. Notwithstanding the foregoing, you may make copies of only portions of the Material for your internal use. You agree to return the Materials and any copies thereof to Honeywell upon the request of Honeywell.

Honeywell

KCS 55/55A

6. Term - This License Agreement is effective until terminated as set forth herein. This License Agreement will terminate immediately, without notice from Honeywell, if you fail to comply with any provision of this License Agreement or will terminate simultaneously with the termination or expiration of your applicable product support agreement, authorized repair facility agreement, or your formal designation as a third party service provider. Upon termination of this License Agreement, you will return these Materials to Honeywell without retaining any copies and will have one of your authorized officers certify that all Materials have been returned with no copies retained.

7. Remedies - Honeywell reserves the right to pursue all available remedies and damages resulting from a breach of this License Agreement.

8. Limitation of Liability - IN NO EVENT WILL HONEYWELL BE LIABLE FOR ANY INCIDENTAL DAMAGES, CONSEQUENTIAL DAMAGES, SPECIAL DAMAGES, INDIRECT DAMAGES, LOSS OF PROFITS, LOSS OF REVENUES, OR LOSS OF USE, EVEN IF INFORMED OF THE POSSIBILITY OF SUCH DAMAGES. TO THE EXTENT PERMITTED BY APPLICABLE LAW, THESE LIMITATIONS AND EXCLUSIONS WILL APPLY REGARDLESS OF WHETHER LIABILITY ARISES FROM BREACH OF CONTRACT, WARRANTY, TORT (INCLUDING BUT NOT LIMITED TO NEGLIGENCE), BY OPERATION OF LAW, OR OTHERWISE.

9. Controlling Law - This License shall be governed and construed in accordance with the laws of the State of New York without regard to the conflicts of laws provisions thereof. This license sets forth the entire agreement between you and Honeywell and may only be modified by a writing duly executed by the duly authorized representatives of the parties.

Copyright - Notice

Copyright 1997-2002, 2007 Honeywell International Inc. All rights reserved.

Honeywell

KCS 55/55A

REVISION HIGHLIGHTS

KCS 55/55A

Part Number	Rev	Date	Description
006-00111-0008	08	Jun/2001	
006-00111-0009	09	Jan/2002	
006-00111-0010	10	Feb/2002	
006-00111-0011	11	Apr/2007	Updated to remove NVG versions of the unit

UP536434

Honeywell

KCS 55/55A

REVISION HIGHLIGHTS

Part Number	Rev	Date	Description

UP536434

BENDIX/KING**KCS 55/55A**

SECTION I GENERAL INFORMATION

<u>PARAGRAPH</u>	<u>PAGE</u>
1.1 SYSTEM COMPONENT DESCRIPTION	1-1
1.2 FUNCTIONAL	1-1
1.3 TECHNICAL CHARACTERISTICS	1-2
1.3.1 KCS 55/55A	1-2
1.3.2 KI 525/525A	1-3
1.3.3 KG 102/102A	1-4
1.3.4 KMT 112	1-5
1.3.5 KA 51/51A	1-5
1.3.6 KA 51B	1-6
1.3.7 KA 52	1-6
1.3.8 KA 57	1-7
1.4 UNITS AND ACCESSORIES SUPPLIED	1-7
1.4.1 KI 525/525A PICTORIAL NAVIGATION INDICATOR	1-7
1.4.2 KG 102/102A DIRECTIONAL GYRO	1-8
1.4.3 KMT 112 MAGNETIC AZIMUTH TRANSMITTER	1-9
1.4.4 KA 51/51A/51B SLAVING ACCESSORY	1-9
1.4.5 KA 52 AUTOPILOT ADAPTER	1-10
1.4.6 KA 57 AUTOPILOT ADAPTER	1-10
1.5 INSTALLATION KITS	1-11
1.6 COMPENSATOR KIT (OPTIONAL)	1-13
1.7 INSTRUCTIONS FOR CONTINUED AIRWORTHINESS	1-13

SECTION II INSTALLATION

<u>PARAGRAPH</u>	<u>PAGE</u>
2.1 UNPACKING AND INSPECTING EQUIPMENT	2-1
2.2 PREINSTALLATION CHECK	2-1
2.3 KI 525/525A INDICATOR INSTALLATION	2-2
2.3.1 GENERAL	2-2
2.3.2 MOUNTING	2-2

BENDIX/KING**KCS 55/55A**

<u>PARAGRAPH</u>	<u>PAGE</u>
2.4 KG 102/102A GYRO INSTALLATION	2-3
2.4.1 GENERAL	2-3
2.4.2 MOUNTING	2-3
2.5 KMT 112 TRANSMITTER INSTALLATION	2-3
2.5.1 GENERAL	2-3
2.5.2 MOUNTING	2-3
2.6 KA 51/51A/51B SLAVING ACCESSORY INSTALLATION	2-3
2.6.1 GENERAL	2-3
2.6.2 MOUNTING	2-3
2.7 ADAPTER INSTALLATION	2-4
2.7.1 KA 52 ADAPTER	2-4
2.7.2 MOUNTING	2-4
2.7.3 KA 57 ADAPTER	2-4
2.7.4 MOUNTING	2-4
2.8 ADJUSTMENTS	2-4
2.8.1 KI 525/525A	2-4
2.8.2 KG 102/102A	2-4
2.8.3 KMT 112	2-4
2.8.4 KA 51/51A	2-4
2.8.5 KA 51B	2-5
2.8.6 ALTERNATE METHOD OF COMPENSATION ADJUSTMENTS FOR KMT 112 AND KA 51/KA 51A	2-6
2.8.7 KA 52 and KA 57	2-7
2.9 AVAILABILITY OF 400 HZ. POWER FROM THE KG 102/102A	2-9

SECTION III OPERATION

<u>PARAGRAPH</u>	<u>PAGE</u>
3.1 DISPLAY DESCRIPTION	3-1
3.1.1 KI 525/525A INDICATOR AND CONTROLS	3-1
3.2 OPERATING PROCEDURES	3-2
3.3 EMERGENCY OPERATION	3-3

BENDIX/KING**KCS 55/55A****LIST OF FIGURES**

<u>FIGURE</u>		<u>PAGE</u>
1-1	KCS 55/55A CRIMPING, INSERTION, AND EXTRACTION TOOLS	1-14
2-1	PIN LOCATIONS	2-10
2-2	KI 525/525A INSTALLATION DRAWING	2-11
2-3	KG 102/102A INSTALLATION DRAWING	2-13
2-4	KMT 112 INSTALLATION DRAWING	2-15
2-5	KA 51 INSTALLATION DRAWING	2-17
2-6	KA 51A INSTALLATION DRAWING	2-19
2-7	KA 51B INSTALLATION DRAWING	2-21
2-8	KA 52 INSTALLATION DRAWING	2-23
2-9	KA 57 INSTALLATION DRAWING	2-24
2-10	KCS 55 COMPASS SYSTEM INTERCONNECT DIAGRAM	2-25
2-11	KCS 55A COMPASS SYSTEM (30HZ OBS RESOLVER) INTERCONNECT DIAGRAM	2-27
2-12	KCS 55A COMPASS SYSTEM (400HZ OBS RESOLVER) INTERCONNECT DIAGRAM	2-29
2-13	KX 175/KN 73/KN 77/KI 525/525A INTERCONNECT DIAGRAM	2-31
2-14	COMPLETE SILVER CROWN SYSTEM INTERCONNECT DIAGRAM	2-33
2-15	KN 72/KN 75/KI 525A INTERCONNECT DIAGRAM	2-37
2-16	KNS 80 - KI 525A INTERCONNECT DIAGRAM	2-39
2-17	KCS 55/55A/BENDIX FCS-810 AUTOPILOT INTERFACE INTERCONNECT	2-42
2-18	KCS 55/55A/CESSNA 300 NAVOMATIC INTERFACE INTERCONNECT	2-43
2-19	KCS 55A/KA 57 CESSNA 300A/CA395A INTERCONNECT	2-44
2-20	KCS 55/55A CESSNA NAVOMATIC 400 INTERFACE INTERCONNECT	2-45
2-21	KCS 55/55A CESSNA NAVOMATIC 400A AUTOPILOT INTERFACE INTERCONNECT	2-46
2-22	KCS 55/55A/CESSNA 400B AUTOPILOT INTERFACE INTERCONNECT	2-47
2-23	KCS 55/55A MITCHELL COUPLER IC-388, 388C, 388M, 388MC INTERFACE INTERCONNECT	2-48
2-24	KCS 55/55A MITCHELL III AUTOPILOT W/IC 388-3 COUPLER INTERFACE INTERCONNECT	2-49
2-25	KCS 55/55A MITCHELL CENTURY IV AUTOPILOT INTERFACE INTERCONNECT	2-50
2-26	KCS 55/55A - AP106/AP107/913K-1 AUTOPILOT INTERFACE INTERCONNECT	2-51
2-27	KLN 90B - KI 525A INTERCONNECT DIAGRAM	2-53
2-28	KG 102/102A 400 Hz. SUPPLY INTERCONNECT DIAGRAM	2-57
3-1	KI 525/525A INDICATOR AND CONTROLS	3-4
3-2	KA 51/51A SLAVING ACCESSORY AND CONTROLS	3-5
3-3	KA 51B SLAVING ACCESSORY AND CONTROLS	3-6

BENDIX/KING

KCS 55/55A

LIST OF TABLES

<u>TABLE</u>		<u>PAGE</u>
1-1	KI 525A VERSION CHART	1-8
1-2	KI 525 VERSION CHART	1-8
1-3	KA 51A VERSION CHART	1-9
1-4	KA 51B VERSION CHART	1-10

SECTION I GENERAL INFORMATION

1.1 SYSTEM COMPONENT DESCRIPTION

The KCS 55/55A Pictorial Navigation System is composed of five units: KI 525/525A Pictorial Navigation Indicator, KG 102/102A Directional Gyro, KMT 112 Magnetic Azimuth Transmitter, KA 51/51A/51B Slaving Accessory, and the KA 52 and KA 57 Autopilot Adapters, if required.

The KI 525/525A Pictorial Navigation Indicator provides a pictorial display of the horizontal navigation situation. The KI 525/525A also provides manual controls for course and heading datum selections. Outputs from the KI 525/525A are for automatic pilot or flight director, VOR receivers and additional compass loads.

The KG 102/102A Directional Gyro is a remote mounted unit which, in conjunction with the KMT 112 Magnetic Azimuth Transmitter, provides a gyro-stabilized magnetic heading to the KI 525/525A Indicator. In addition to the slaving circuitry this unit contains an internal power supply which provides excitation voltages for the Magnetic Azimuth Transmitter and positive and negative D.C. voltages for the Pictorial Navigation Indicator and the Slaving Accessory.

The KMT 112 Magnetic Azimuth Transmitter senses the direction of the earth's magnetic field and transmits this information to the Pictorial Navigation Indicator.

The KA 51/51A/51B Slaving Accessory is a panel mounted unit which contains the slaving meter, slaving switches, and corrector circuitry which compensates for the effect of local magnetic disturbances on the Magnetic Azimuth Transmitter.

The KA 52 Autopilot Adapter is an optional remote mounted device that converts the DC heading and course datum signals from the Pictorial Navigation Indicator into two separate AC signals compatible with certain autopilot systems.

The KA 57 Autopilot Adapter is an optional remote mounted device that converts the DC heading and course datum signals from the KI 525/525A Indicator into a single, switchable AC output signal compatible with certain autopilot systems.

1.2 FUNCTIONAL

(KCS 55 System)

When power is first applied to the KCS 55 System, and the system is in the slaved gyro mode, the heading display will automatically fast slave at the rate of 180 degrees per minute to align the slaving control transformer in the KI 525 with the magnetic heading transmitted by the KMT 112. The system will remain in this fast slave mode for 120 seconds after which it will automatically revert to the normal slaving mode and slave at a constant rate of 3 degrees per minute to keep the system aligned with the earth's magnetic field. If the system is cycled from the free gyro mode to the slaved gyro mode by means of actuating the "slave in" button on the KA 51 the "fast slave" will automatically be repeated.

(KCS 55A System)

When power is first applied to the KCS 55A System, and the system is in the slaved gyro mode, the heading display will automatically fast slave at the rate of 180 degrees per minute to align the slaving control transformer in the KI 525A with the magnetic heading transmitted by the KMT 112. The system will remain in this fast slave mode until the slaving error is reduced to zero and then revert to the normal slaving mode and slave at a constant rate of 3 degrees per minute to keep the system aligned with the earth's magnetic field. If the system is cycled from the free gyro mode to the slaved gyro mode by means of actuating the "slave in" button on the KA 51A (toggle switches on the KA 51B), the "fast slave" will automatically be repeated.

The tumble detect version, (KG 102A, P/N 060-0015-02), while in slaved gyro mode will automatically switch the system to fast slave mode when rates exceed approximately 25 degrees per second. Once the system display (KI 525/525A) matches earth's magnetic field +/- 2 degrees, the system will revert back to slow slave mode.

Stabilized heading information is supplied to the KI 525/525A by the KG 102/102A. When in the slaved gyro mode this heading signal, which may vary at rates up to 30 degrees/second, is summed with the normal slaving signal from the KMT 112 to provide the final drive signal for the heading display.

When the system is in the free gyro mode the heading signal from the KG102/102A is the only input to the heading display drive. While in the free gyro mode the pilot may command changes in the displayed heading by means of depressing the clockwise or counterclockwise push buttons on the KA 51/51A (toggle switches on the KA 51B).

1.3 TECHNICAL CHARACTERISTICS

1.3.1 KCS 55/55A

SPECIFICATION	CHARACTERISTIC
TSO COMPLIANCE:	TSO C6c
	RTCA DO-138 Environmental Categories
	KI 525/525A, versions 00-03 & 10-12 DAMAAAXXXXXX
	KI 525A versions 04-08 DAPAAAXXXXXX
	KA 51/51A: DAMAAAXXXXXX
	KA 51B: (see section 1.3.6)
	KG 102, KA 52; KA 57: BAJAAAXXXXXX
	KG 102A: BA/JN/AAAXXXXXX
	KMT 112: BA/SV/AAAXXXXXX
SYSTEM ACCURACY:	Accurate to within 2° of local magnetic heading.
POWER REQUIREMENTS:	14VDC 15.8 max., 3.23 A 11.0 min.
	28VDC 31.6 max., 1.73 A 22.0 min.
	5VDC .4 A
SLAVING RATE:	Normal: 3 degrees per minute Fast: 180 degrees per minute
SLAVING SENSITIVITY: and	±0.5° when in a field strength of Hx = 0.18 gauss
	Hz = 0.54 gauss.
WARM-UP TIME:	Varies from 1 min. at +55°C to 5 min. at -46°C.

1.3.2 KI 525/525A

BENDIX/KING**KCS 55/55A**

SPECIFICATION	CHARACTERISTIC
SIZE:	See Fig. 2-2
WEIGHT:	See Fig. 2-2
MOUNTING:	Flanged mounted through front of the instrument panel.
MATING CONNECTORS:	See Paragraph 1.5 Installation Kits
POWER INPUTS:	14VDC, .36 amps or 28VDC, .27 amps (required for lighting and NAV flag power); ± 15 VDC, ± 5 VDC (provided by the KG 102/102A)
	Heading synchro transmitter: Requires a 26 volt, 400Hz rotor excitation for a 3-wire stator output equal to 206 millivolts per degree of heading rotation. (066-3029-01, 066-3046-01/03/05/07/08/10/11/12 indicators only).
SIGNAL INPUTS:	Slaving control transformer; 3-wire stator input from the KMT 112.
	VOR/LOC deviation meter: 150 ± 20 microamperes through a resistance of 1000 ± 30 ohms for a full scale deflection of five dots.
	To-From pointer 200 ± 40 microamperes through a resistance of 200 ± 30 ohms for full deflection.
	NAV warning flag: Disappears from view with an input of 225 ± 15 microamperes through a resistance of 1000 ± 30 ohms.
	Glideslope deviation pointers: 150 ± 20 micro amperes through a resistance of 1000 ± 30 ohms for a full scale of two dots.
	Glideslope flag input: 230 ± 50 microamperes through a resistance of 1000 ± 30 ohms. When glideslope is valid and after a 2 to 12 second delay pointers will come into view displaying deviation.
	30Hz Course resolver: Omnirange zeroed at 300 degrees for 30Hz. Electrically equivalent to Clifton TWH-11-F-08.
	400Hz Course resolver: Electrically zeroed at 300 degrees for 400Hz. Electrically equivalent to Clifton TSH-11-F-08. (066-3046-02/03/06/07/11/12 indicators only)
	Drive signal for the heading loop drive motor from the KG 102/102A.

1.3.2

KI 525/525A (cont).

BENDIX/KING

KCS 55/55A

SPECIFICATION	CHARACTERISTIC
SIGNAL OUTPUTS:	Heading synchro transmitter: Output equal to 206 millivolts per degree of heading rotation. (066-3029-01 and 066-3046-01/03/05/07/08/10/11/12 Indicators only)
	Selected heading error output: An internally excited transducer which supplies an error output equal to 0.55 volts D.C. per degree of displacement from the lubber line.
	Selected course error output: An internally excited transducer which supplies an error output equal to .21 volts D.C. per degree of displacement from the lubber line.

1.3.3 KG 102/102A

SIZE:	See Fig. 2-3
WEIGHT:	See Fig. 2-3
MOUNTING:	Shock mounted (provided in installation kit)
MATING CONNECTOR:	See Paragraph 1.5 Installation Kits
POWER INPUTS:	14VDC, 3.0 amperes or 28VDC, 1.5 amperes
SIGNAL INPUTS:	Slaving error control transformer from the KI525/525A.
POWER OUTPUTS:	±15 and +5VDC reference voltages for the KI525/525A and the KA 51/51A/51B.
	A 7.2 VRMS, 400 Hz drive signal for the primary excitation of the KMT 112 and for use in the KA 51/51A/51B.
	A 5 VA maximum of 26 VAC, 400 Hz power is available for all uses.
SIGNAL OUTPUTS:	A drive signal for the heading loop drive motor in the KI 525/525A.
	Slaving meter drive signal for the KA 51/51A/51B.
(KG 102A Only)	Pin <u>a</u> supplies a ground when compass system is valid.

1.3.4 KMT 112

BENDIX/KING

KCS 55/55A

SIZE:	See Fig. 2-4
WEIGHT:	See Fig. 2-4
MOUNTING:	Rigid mount with three #6 non-magnetic screws in a remote magnetically stable area.
MATING CONNECTOR:	See paragraph 1.5 Installation Kits
POWER INPUT:	7.2VRMS, 400Hz from the KG 102/102A.
SIGNAL OUTPUT:	An 800Hz synchro control transmitter type output to the KI 525/525A

1.3.5 KA 51/51A

SPECIFICATION	CHARACTERISTIC
SIZE:	See Fig. 2-5 and 2-6
WEIGHT:	See Fig. 2-5 and 2-6
MATING CONNECTOR:	See paragraph 1.5 Installation Kits
POWER INPUTS:	+5VDC from KG 102/102A
	7.2 VAC 400Hz from KG 102/102A
KA 51A (071-1053-03)	+14VDC Lamp Supply
KA 51A (071-1053-04)	+28VDC Lamp Supply
SIGNAL INPUTS:	Slaving meter drive signal from the KG 102/102A
SIGNAL OUTPUTS:	Magnetic Azimuth Transmitter compensation outputs for North/South and East/West correction to the KI 525/525A.
	Clockwise and counterclockwise manual slave signals to the KG 102/102A
	Slaved/free gyro mode logic signal to the KG 102/102A

1.3.6 KA 51B

BENDIX/KING

KCS 55/55A

SPECIFICATION	CHARACTERISTIC
SIZE:	See Fig. 2-7
WEIGHT:	See Fig. 2-7
TSO:	C6c, DO-138 Env. Cat. DANAAAXXXXXX
POWER INPUTS:	+5VDC from KG 102A or +12VDC from KSG 105 7.2VAC 400Hz from KG 102A or 26VAC 400Hz from KSG 105
	+5VDC Lamp Supply (-03 version)
	+14VDC Lamp Supply (-00/-05 version)
	+28VDC Lamp Supply (-01/-02/-04/-06 versions)
SIGNAL INPUTS:	Slaving meter drive signal from the KG 102A/KSG 105.
SIGNAL OUTPUTS:	Magnetic Azimuth Transmitter compensation outputs for North/South and East/West correction.
	Clockwise and counterclockwise manual slew signals to the KG 102A/KSG 105.
	Slave/free gyro mode logic signal to the KG 102A/KSG 105.

1.3.7 KA 52

SPECIFICATION	CHARACTERISTIC
SIZE:	See Fig. 2-8
WEIGHT:	See Fig. 2-8
MOUNTING:	Rigid mount with four #6 screws.
MATING CONNECTOR:	See paragraph 1.5 Installation Kits
POWER INPUTS:	±15 volts DC from the KG 102/102A
SIGNAL INPUTS:	Heading select DC input from the KI 525/525A
	Course datum DC input from the KI 525/525A
	AC reference input from the aircraft autopilot system at 5 volts R.M.S. minimum.
SIGNAL OUTPUTS:	Heading select AC output transformer isolated and phase locked to the reference input from the autopilot.
	Course datum AC output transformer isolated and phase locked to the reference input from the autopilot.

1.3.8 KA 57

BENDIX/KING**KCS 55/55A**

SIZE: x 10.20 centimeters)	See Fig. 2-9
WEIGHT:	See Fig. 2-9
MATING CONNECTOR:	See paragraph 1.5 Installation Kits
POWER INPUTS:	±15 volts DC from KG 102/102A
SIGNAL INPUTS:	Heading select DC input from the KI 525/525A Course datum DC input from the KI 525/525A AC reference input from aircraft autopilot system at 7 volts R.M.S. minimum.
	Localizer Normal - ground when radio coupler selector switch is at LOC Normal.
	Localizer Energized - ground when NAV 1 receiver tuned to localizer frequency.
SIGNAL OUTPUTS:	Heading select AC or course datum AC output transformer isolated and phase locked to the reference input from the autopilot.

1.4 UNITS AND ACCESSORIES SUPPLIED

1.4.1 KI 525/525A PICTORIAL NAVIGATION INDICATOR

The KI 525/525A is an internally lighted unit that displays a gyro-stabilized aircraft magnetic heading, selected course, selected heading. VOR and localizer course deviation, glideslope deviation and a TO-FROM indication for VOR flight.

In addition, warning flags are provided to signify unusable VOR/Localizer information (NAV Flag) and to indicate a valid compass system (HDG Flag). The glideslope pointer will retract from view when an unusable glideslope signal is being received.

A bootstrap heading synchro is provided as a source of slaved heading information, and heading and course select transducers provide DC signals for autopilot or flight direction information. Either of two types of course resolver is provided depending on which part number unit is chosen.

All part numbers are capable of operating at 30Hz. However, 066-03046-02/03/06/07/11/12 are capable of operating at either 30Hz or 400Hz. Serial number 43434 and above have glideslope damping for helicopters in all versions.

PN	BEZEL	OBS	LIGHTING	HDG XMTR
066-3046-00	BLACK	30 HZ	14/28 V	
066-3046-01	BLACK	30 HZ	14/28 V	X
066-3046-02	BLACK	30/400 HZ	14/28 V	
066-3046-03	BLACK	30/400 HZ	14/28 V	X
066-3046-04	BLACK	30 HZ	14/28 V	
066-3046-05	BLACK	30 HZ	14/28 V	X
066-3046-06	BLACK	30/400 HZ	14/28 V	
066-3046-07	BLACK	30/400 HZ	14/28 V	X
066-3046-08	BLACK	30 HZ	5 V	X
066-3046-10	GRAY	30 HZ	5 V	X
066-3046-11	GRAY	30/400 HZ	5 V	X
066-3046-12	BLACK	30/400 HZ	5 V	X

Table 1-1 KI 525A Version Chart

PN	BEZEL	LIGHTING	OBS	HDG XMTR
066-3029-00	BLACK	14/28 VDC	30 HZ	
066-3029-01	BLACK	14/28 VDC	30 HZ	X

Table 1-2 KI 525 Version Chart

1.4.2 KG 102/102A DIRECTIONAL GYRO

The KG 102/102A Directional Gyro is a remote mounted unit which, in conjunction with the KMT 112 Magnetic Azimuth Transmitter, provides a gyro stabilized magnetic heading to the KI 525/525A Indicator. In addition to the slaving circuitry the KG 102/102A contains an internal power supply which provides gyro rotor power, excitation voltages for the Magnetic Azimuth Transmitter, and positive and negative D.C. voltages for the Pictorial Navigation Indicator and the Slaving Accessory.

PN 060-0011-00 is the only version available for the KG 102. The KG 102A is available in a standard version (PN 060-0015-00), a version with RFI filter (PN 060-0015-01), and a version with RFI filter and tumble detection (PN 060-0015-02).

1.4.3 KMT 112 MAGNETIC AZIMUTH TRANSMITTER

The KMT 112 (PN 071-1052-00) senses the direction of the earth's magnetic field and transmits this information to the KI 525/525A.

1.4.4 KA 51/51A/51B SLAVING ACCESSORY

BENDIX/KING

KCS 55/55A

The KA 51 Slaving Accessory (PN 071-1053-00) is a panel mounted unit that displays the slaving error between the KMT 112 and the KI 525 by means of a small meter movement.

The KA 51A/51B Slaving Accessory is an internally lighted panel mounted unit that displays the slaving error between the KMT 112 and KI 525A by means of a small meter movement.

KA 51A, three pushbutton switches are provided below the slaving meter. The center switch is an alternate action switch that engages the "slaved gyro" mode when depressed. When the switch is in its outer position the KCS 55/55A is in the "free gyro" mode. The other two pushbutton switches are momentary switches and provide clockwise and counterclockwise manual slaving whenever the system is in the "free gyro" mode.

The KA 51/51A also contains circuitry through which hard-iron effects upon the KMT 112 can be compensated by the adjustment of two potentiometers. Access holes labeled N/S and E/W are provided on the front surface of the KA 51/51A for access to these two potentiometers.

The KA 51B, houses two toggle switches below the slaving meter. The switch nearest the meter (SLAVE/FREE) is a lockout type toggle switch that engages the slaved gyro mode when in the slave position and places the KCS 55A/KCS 305 in the free gyro mode when in the free position. The lower switch (CW/CCW) is a momentary left and right toggle switch and provides clockwise and counterclockwise manual slewing whenever the system is in the free gyro mode.

The KA 51B also contains circuitry through which hard iron effects upon the KMT 112 can be compensated by the adjustment of two potentiometers. Access holes labeled N/S and E/W are provided on the side of the unit for access to the two potentiometers.

PN	BEZEL	LIGHTING
071-1053-00	BLACK	NONE
071-1053-01	BLACK	5 V
071-1053-02	GRAY	5 V
071-1053-03	BLACK	14 V
071-1053-04	BLACK	28 V
071-1053-05	GRAY	28 V
071-1053-06	BLACK	5 V RED
071-1053-07	GRAY	5 V RED
071-1053-08	GRAY	14 V
071-1053-09	BLACK	28 V RED

Table 1-3 KA 51/51A Version Chart

BENDIX/KING**KCS 55/55A**

PN	BEZEL	LIGHTING	FACEPLATE
071-1242-00	BLACK	14 V	VERTICAL
071-1242-01	BLACK	28 V	VERTICAL
071-1242-02	GRAY	28 V	VERTICAL
071-1242-03	BLACK	5 V RED	VERTICAL
071-1242-04	BLACK	28 V RED	VERTICAL
071-1242-05	BLACK	14 V	HORIZONTAL
071-1242-06	BLACK	28 V	HORIZONTAL
071-1242-07	GRAY	5 V	HORIZONTAL
071-1242-08	GRAY	5 V	VERTICAL
071-1242-09	GRAY	28 V	HORIZONTAL
071-1242-10	BLACK	5 V	VERTICAL
071-1242-11	BLACK	5 V	HORIZONTAL
071-1242-13	GRAY	5 V	VERTICAL
071-1242-14	GRAY	5 V	HORIZONTAL

Table 1-4 KA 51B Version Chart**1.4.5 KA 52 AUTOPILOT ADAPTER**

The KA 52 Autopilot Adapter is an optional remote mounted device that converts the DC heading and course datum signals from the KI 525/525A Indicator into two separate AC signals compatible with certain autopilot systems. PN 071-1055-00 is the standard version. PN 071-1055-01 is available when 115 V 400 Hz ref. is needed by Radar for Stabilization.

1.4.6 KA 57 AUTOPILOT ADAPTER

The KA 57 Autopilot Adapter (PN 071-0017-00) is an optional remote mounted device that converts the DC heading and course datum signals from the KI 525/525A Indicator into a single, switchable AC output signal compatible with certain autopilot systems.

1.5 INSTALLATION KITS

See figure 1-1 for crimping, insertion, and extraction tools.

BENDIX/KING

KCS 55/55A

- A. KI 525/525A Installation Kit P/N 050-01344-0000 (solder connector), -0001 (solder connector with extended knob), and -0002 (crimp connector) includes the following:

PN	Description	Qty		
		-0000	-0001	-0002
030-01080-0001	Conn, FM Crmp 20 AWG			24
030-01081-0001	Conn, ML Crmp 20 AWG			41
030-02153-0000	Conn, 24 Pin	1	1	
030-02154-0000	Conn, Hood	2	2	2
030-02178-0000	Conn, Plug 41 Pin	1	1	
030-02272-0000	Conn, 41P Shell			1
030-02272-0001	Conn Shell, 41 Pin, Male			1
047-03937-0001	Plate, Nut	1	1	1
057-02105-0016	Decal, Cut out	1	1	1
076-00904-0001	Spacer, Knob	-	2	2
089-05115-0012	Scr. PFH #6-32 x 3/4	4	4	4

- B. KMT 112 Installation Kit (050-01361-0000) includes the following:

PN	Description	Qty.
030-02190-0000	Conn, 5 Pin	1
089-02157-0015	Nut, Hex #6-32	3
089-07009-0010	Scr. SPH #6-32 x 5/8	3
089-08036-0019	Washer #6	6

- C. KG 102A Installation Kit P/N 050-01410-0001 (solder connector), -0002 (crimp connector), and -0050 includes the following:

PN	Description	QTY.		
		-01	-02	-50
030-01080-0001	Conn, FM Crmp		37	
030-02154-0000	Conn, Hood	1	1	1
030-02221-0000	Conn, Rec. 37 Pins	1		1
030-02272-0000	Conn, 41P Shell		1	
057-01611-0000	Shock Mount Hole Temp	1	1	
071-04025-0001	Assy Vibration Mount	1	1	
089-05909-0009	Scr. #8-32 X 9/16 PHP	2	2	
155-02001-0000	GND Strap	1	1	

The shock mount assembly (P/N 071-04025-0001) contains the following:

BENDIX/KING**KCS 55/55A**

PN	Description	Qty.
047-03221-0002	Mounting Rack	1
052-00008-0002	Shock Mount	4
089-06073-0006	Screw FHP 8-32X3/8	4

D. KA 51A Installation Kit (050-01428-00/-01) includes the following:

PN	Description	-00	-01
030-02224-0000	Conn, 14 Pin	1	1
088-00450-0000	Conn, Hood	1	1
089-05899-0007	Scr., PHP, 2-56 X 7/16	2	2
089-06163-0008	Scr., FHP #4-40 X 1/2	4	
089-06596-0008	Scr., FHP #4-40 X 1/2		4
089-08163-0001	Washer, Flat #2	2	2

E. KA 51 Installation Kit (050-01362-0000) includes the following:

PN	Description	Qty.
030-00107-0000	Conn, 12 Pin	1
088-00405-0000	Conn, Hood	1
089-05111-0008	Scr. PHF #4-40 x 1/2	4
089-06414-0007	Scr. PHP #2-28 x 7/16	2

F. KA 52 Installation Kit (050-01390-0000) includes the following:

PN	Description	Qty.
030-00107-0011	Conn, 12 Pin	1
088-00450-0000	Conn, Hood	1
089-05903-0007	Scr. PHP #4-40 x 7/16	2

G. KA 57 Installation Kit (050-01421-0000) includes the following:

PN	Description	Qty.
030-00107-0016	Conn, 20 Pin	1
088-00438-0000	Conn, Hood	1
089-05903-0006	Scr. PHP #4-40 x 3/8	2

BENDIX/KING**KCS 55/55A**

H. The KA 51B Installation Kit 050-01928-0000 contains the following:

PN	Description	Qty.
030-02421-0000	9 Pin Connector	1
030-02423-0000	5 Pin Connector	1
047-05759-0002	Mtg. Ring	1
047-05760-0002	Mtg. Plate	1
089-06163-0008	Scr., FHP #4-40 X 1/2	2

1.6 COMPENSATOR KIT (OPTIONAL)

Also available, is an optional Compensator Kit (050-01928-0001) for installations where the installer wishes to use a different switch/meter arrangement. The Compensator Kit PN 050-01928-0001 contains the following:

PN	Description	Qty.
030-02423-0000	5 Pin Connector	1
047-05760-0002	Mtg. Plate	1
200-02846-0000	Compensator Assembly	1

1.7 INSTRUCTIONS FOR CONTINUED AIRWORTHINESS

The instructions for continued airworthiness given in the TC or STC approvals for this product supplements or supersedes the instructions for continued airworthiness in this manual.

Most Honeywell products are designed and manufactured to allow "on condition maintenance." On condition maintenance is described as follows; There are no periodic service requirements necessary to maintain continued airworthiness. No maintenance is required until the equipment does not properly perform its intended function. When service is required, a complete performance test should be accomplished following any repair action. Consult the appropriate unit Maintenance/Overhaul Manual for complete performance test information.

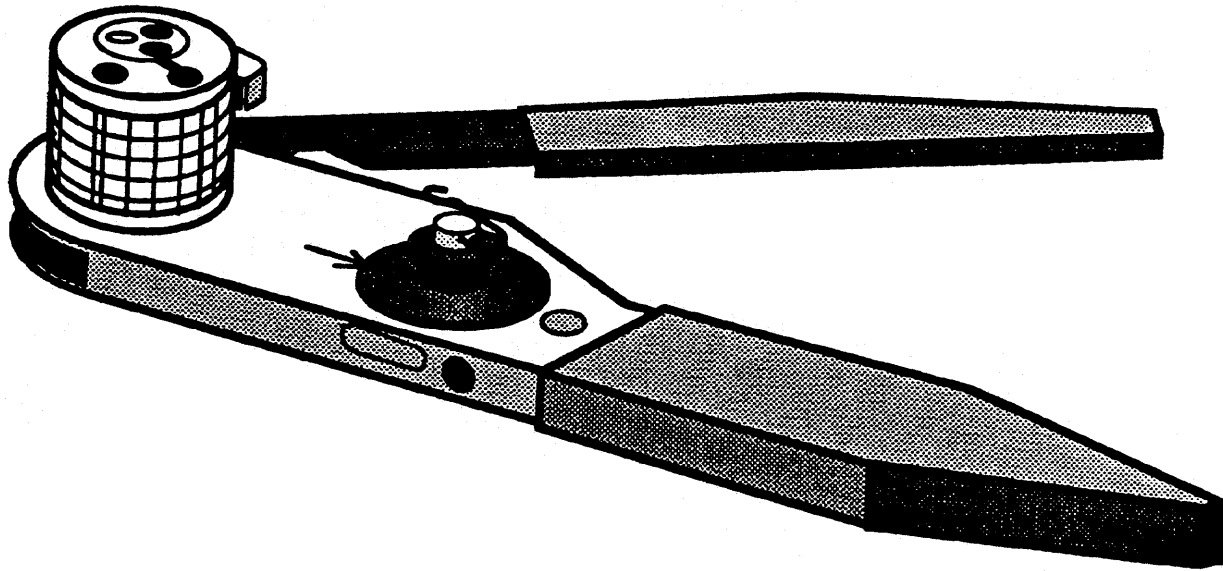

CRIMPING TOOL

HONEYWELL P/N 005-02012-0017

POSITRONICS P/N 9501

DANIELS P/N M22520/1-01

POSITIONER

HONEYWELL P/N 005-02012-0018

POSITRONICS P/N 9502-1

DANIELS P/N M22520/1-03

CRIMPING TOOL / POSITIONER

BUCHANAN P/N 615710

INSERTION TOOL (NOT PICTURED)

HONEYWELL P/N 005-02012-0015

POSITRONICS P/N 9099

EXTRACTION TOOL (NOT PICTURED)

HONEYWELL P/N 005-02012-0012

POSITRONICS P/N 9081

FIGURE 1-1 KCS 55/55A CRIMPING, INSERTION, AND EXTRACTION TOOLS

SECTION II INSTALLATION

2.1 UNPACKING AND INSPECTING EQUIPMENT

Exercise extreme care when unpacking the equipment. Make a visual inspection of the unit for evidence of damage incurred during shipment. If a claim for damage is to be made, save the shipping container to substantiate the claim. The claim should be promptly filed with the transportation company. It would be advisable to retain the container and packaging material after all equipment has been removed in the event that equipment storage or reshipment should become necessary. The conditions and tests required for TSO approval of this article are minimum performance standards. It is the responsibility of those desiring to install this article either on or within a specific type or class of aircraft to determine that the aircraft installation conditions are within TSO standards. The article may be installed only if further evaluation by the applicant documents an acceptable installation and is approved by the Administrator.

NOTE

THE KG 102/102A CONTAINS A VERY SENSITIVE GYRO. IN ORDER TO PREVENT DAMAGE DURING SHIPMENT ALL SHIPMENTS MUST BE MADE IN THEIR ORIGINAL PACKING CONTAINERS.

2.2 PREINSTALLATION CHECK

The equipment has been completely tested before leaving the factory. To ensure that the equipment has not been damaged in shipment, it is suggested that the preinstallation bench test be performed. The bench test harness or aircraft cables wired per Figures 2-9 and 2-10 are required for this test. Inputs and performance are indicated in the component technical characteristics specifications, paragraph 1.4.1 through 1.4.6.

WARNING

IT HAS BEEN DETERMINED THAT THE KCS 55/ KCS 55A PICTORIAL NAVIGATION SYSTEM AND ITS ASSOCIATED KA 52 AND/OR KA 57 AUTOPILOT ADAPTORS ARE NOT FULLY COMPATIBLE WITH THE PIPER ALTIMATIC II AUTOPILOT.

HONEYWELL SUGGESTS THAT NO ATTEMPT BE MADE TO INTERFACE THE KCS 55/55A SYSTEM WITH THE ALTIMATIC II OR ANY OTHER "RF SENSING DESIGN" AUTOPILOT SYSTEM.

CAUTION:

EXTREME CAUTION SHOULD BE TAKEN TO ENSURE THAT 28 VOLTS DC IS NOT APPLIED TO UNITS THAT ARE SWITCHED TO THE 14 VOLTS DC POSITION ON THE KG 102/102A.

NOTE:

FOR THE CENTURY 21/31/41 AUTOPILOT INTERFACES, AN IC 930 ADAPTER IS AVAILABLE FROM CENTURY FLIGHT SYSTEMS. CONTACT AT TEL: (817) 325-2517.

BENDIX/KING**KCS 55/55A****CAUTION:**

THE FOLLOWING PRECAUTIONS MUST BE OBSERVED WHILE FABRICATING THE SYSTEM INSTALLATION HARNESS AND REMOVING/REINSTALLING UNITS FOR MAINTENANCE. TO AVOID CONNECTOR DAMAGE:

1. WHEN FABRICATING THE INSTALLATION HARNESS FOR THE KCS 55/KCS 55A SYSTEM, SUFFICIENT STRAIN RELIEF SHOULD BE LEFT IN THE HARNESS AT THE CONNECTORS SO AS NOT TO APPLY ANY UNDUE STRESS TO THEM.
2. SYSTEM CONNECTORS SHOULD BE INSPECTED FOR POSSIBLE DAMAGE DURING REMOVAL AND REINSTALLATION.
3. CARE SHOULD BE TAKEN WHEN MATING THE CONNECTORS TO INSURE THAT THE PINS ENGAGE WITHOUT UNDUE FORCE SO AS NOT TO DAMAGE PINS IN EITHER CONNECTOR. DAMAGED CONNECTORS WILL COME UNDER CLOSE INSPECTION TO DETERMINE THE VALIDITY OF ANY WARRANTY CLAIMS.
4. AFTER INSTALLATION OF THE CABLING AND BEFORE INSTALLATION OF THE EQUIPMENT, A CHECK SHOULD BE MADE WITH AIRCRAFT PRIMARY POWER SUPPLIED TO THE MOUNTING CONNECTOR. THIS WILL ENSURE THAT POWER IS APPLIED ONLY TO THE PINS SPECIFIED IN THE INTERCONNECTION DIAGRAMS.

The TSO identifies the minimum performance standards, tests, and other conditions applicable for issuance of design and production approval of the article. The TSO does not specifically identify acceptable conditions for installation of the article. The TSO applicant is responsible for documenting all limitations and conditions suitable for installation of the article. An applicant requesting approval for installation of the article within a specific type or class of product is responsible for determining environmental and functional compatibility.

2.3 KI 525/525A INDICATOR INSTALLATION

2.3.1 GENERAL

The KI 525/525A is an internally lighted panel mounted unit that provides compass heading and navigation information for the pilot. Location for the mounting of this unit should be such that it will be easily viewed, preferably directly in front of the pilot, with a minimum of parallax.

2.3.2 MOUNTING

The KI 525/525A is mounted from the front of the aircraft panel and should be secured per Figure 2-2 with four #6-32 screws that are provided with the unit. Using the connectors provided connect the system wiring and the navigation and lighting wiring per Figures 2-10, 2-11, 2-12 and 2-13.

BENDIX/KING**KCS 55/55A**

2.4 KG 102/102A GYRO INSTALLATION

2.4.1 GENERAL

The KG 102/102A Gyro is a remote mounted unit that provides gyro stabilized magnetic heading to the KI 525/525A Indicator when coupled to the KMT 112 Transmitter.

2.4.2 MOUNTING

The KG 102/102A may be mounted in any convenient location. The mounting surface should be such that when the aircraft is in level flight the mounting surface of the KG 102/102A will be level within ± 5 degrees in any direction. The unit should be secured with two #8 screws into the vibration mount per Figure 2-3. Using the connector furnished with the unit connect the wiring as shown in the Figures 2-9 and 2-10.

2.5 KMT 112 TRANSMITTER INSTALLATION

2.5.1 GENERAL

The KMT 112 Transmitter detects the horizontal component of the earth's magnetic field and transmits them to the KI 525/525A Indicator for use as long term correction information.

2.5.2 MOUNTING

The KMT 112 should be located as far as possible from all sources of local magnetic disturbances such as engines, electrical cables, or radio equipment. A wing tip or tail section location will usually be satisfactory. The use of a hand held compass can be helpful in determining if the selected area is free of magnetic disturbance. The mounting surface should be such that when the aircraft is in level flight the mounting flange of the KMT 112 will be level within ± 2 degrees. The unit should be secured per Figure 2-4 with the three #6-32 non-magnetic screws and associated non-magnetic hardware that are provided with the unit. Using the connector provided connect the wiring to the unit as shown in Figures 2-9 and 2-10.

2.6 KA 51/51A/51B SLAVING ACCESSORY INSTALLATION

2.6.1 GENERAL

The KA 51/51A/51B Slaving Accessory is a panel mounted unit that contains the slaving meter, slaving switches, and corrector circuitry which compensates for the effect of local magnetic disturbances. The KA 51A/51B is internally lighted.

2.6.2 MOUNTING

The KA 51/51A is mounted from the front of the aircraft panel and should be secured per Figure 2-5, 6 with four #4-40 screws that are provided with the unit. Using the connector provided connect the wiring to the unit as shown in Figure 2-9 and 2-10.

The KA 51B is mounted from the front of the aircraft panel (the compensator assembly may be remote mounted) and is secured per Figure 2-1 with two #4-40 screws provided in the installation kit. Using the connector provided, connect the wiring to the unit as shown in Figure 2-2.

BENDIX/KING**KCS 55/55A**

2.7 ADAPTER INSTALLATION

2.7.1 KA 52 ADAPTER

The KA 52 is an optional remote mounted unit that converts the DC heading and course datum signals from the KI 525/525A to AC signals compatible with certain autopilot systems.

2.7.2 MOUNTING

The KA 52 may be mounted in any convenient location with four #6 screws per Figure 2-7. It is suggested that the unit be mounted so that it is accessible in flight in order for service personnel to perform alignment adjustments for optimum performance. The mating connector is furnished with the unit. Figures 2-9 and 2-10 shows a typical installation that incorporates the KA 52.

2.7.3 KA 57 ADAPTER

The KA 57 is an optional remote mounted unit that converts the DC heading and course datum signals from the KI 525/525A into an AC signal compatible with certain autopilots that have a single input. The KA 57 has a single output, Heading Select or Course Datum, that is determined by the Autopilot switching.

2.7.4 MOUNTING

The KA 57 may be mounted in any convenient location with four #6 screws per Figure 2-8. It is suggested that the unit be mounted so that it is accessible in flight in order for service personnel to perform alignment adjustments for optimum performance. The mating connector is furnished with the unit.

2.8 ADJUSTMENTS

2.8.1 KI 525/525A

No adjustments are required.

2.8.2 KG 102/102A

A switch located on the top surface of the KG 102/102A has a 14 volt and a 28 volt position. This switch must be set in the position that corresponds with the input DC voltage. To change the switch position remove the switch cover, set the switch in the desired position, then re-install the switch cover. The correct input DC voltage (14 or 28) should then be seen through the switch cover.

2.8.3 KMT 112

With the complete KCS 55/55A system operating and synchronized, position the aircraft on a compass rose and turn it to each of the four cardinal headings. Place the KA 51/51A/51B in the "Free Gyro" mode and center the slave meter with the manual slave buttons on the KA 51/51A (toggle switches on the KA 51B) at each of these headings. Record the algebraic error between the compass rose and the heading on the KI 525/525A. Add the algebraic errors and divide by four to obtain the index error.

Loosen the mounting screws on the KMT 112 and rotate the unit an amount equal to the index error to cancel-out the index error. Retighten the mounting screws. This procedure should be repeated after the N/S E/W compensator has been adjusted (see paragraph 2.8.4).

2.8.4 KA 51/51A

With the complete KCS 55/55A system operating and the KA 51/51A in the "free gyro" mode; position the aircraft on a compass rose and adjust the compensator as follows:

BENDIX/KING**KCS 55/55A**

- A. Place the aircraft on a North heading and rotate the compass card to NORTH with the manual slave buttons. Place a non-magnetic blade screwdriver in the N/S opening on the KA 51/51A and center the slave meter.
- B. Place the aircraft on an East heading and rotate the compass card to EAST with the manual slave buttons. Place a non-magnetic blade screwdriver in the E/W opening on the KA 51/51A and center the slave meter.
- C. Place the aircraft on a South heading and rotate the compass card to SOUTH with the manual slave buttons. Place a non-magnetic blade screwdriver in the N/S opening on the KA 51/51A and adjust the meter for one-half of the existing meter deviation.
- D. Place the aircraft on a West heading and rotate the compass card to WEST with the manual slave buttons. Place a non-magnetic blade screwdriver in the E/W opening on the KA 51/51A and adjust the meter for one-half of the existing meter deviation.

To achieve maximum accuracy of the system the index-error of the KMT 112 should be re-adjusted per paragraph 2.8.3 above. All reading should be within ± 2 degrees of those on the compass rose.

2.8.5 KA 51B

With the complete KCS 55A Compass System operating and the KA 51B in the "Free Gyro" mode, position the aircraft on a compass rose. Remove the two mounting screws that secure the unit to the panel and slide the unit out until the meter test jacks and compensator potentiometers are accessible. If the compensator assembly is remote mounted, gain access to the compensator potentiometers. Connect a digital millivolt meter to the unit test jacks (common connection of the millivolt meter to the black test jack of the KA 51B and positive connection of the millivolt meter to the red test jack of the KA 51B). Adjust the compensation as follows:

- A. Place the aircraft on a North heading and center the compass card North under the Lubber line with the CW/CCW switch. Place a non-magnetic blade screwdriver in the N/S potentiometer in the KA 51B Compensator Assembly and zero the external millivolt meter ($0.0\text{VDC} \pm 50\text{mV}$).
- B. Place the aircraft on an East heading and center the compass card East under the Lubber line with the CW/CCW switch. Place a non-magnetic blade screwdriver in the E/W potentiometer in the KA 51B Compensator Assembly and zero the external millivolt meter ($0.0\text{VDC} \pm 50\text{mV}$).
- C. Place the aircraft on a South heading and center the compass card South under the Lubber line with the CW/CCW switch. Place a non-magnetic blade screwdriver in the N/S potentiometer in the KA 51B Compensator Assembly and adjust the external millivolt meter for 1/2 of the existing millivolt meter readout.
- D. Place the aircraft on a West heading and center the compass card West under the Lubber line with the CW/CCW switch. Place a non-magnetic blade screwdriver in the E/W potentiometer in the KA 51B Compensator Assembly and adjust the external millivolt meter for 1/2 of the existing millivolt meter readout.

As a final check of the KCS 55A Compass System, position the aircraft on the compass rose and turn to each of the four cardinal headings while the KCS 55A System is in the Slaved Gyro mode. All readings should be within $\pm 2^\circ$ of those on the compass rose. The KA 51B can now be re-secured to the aircraft panel. The alignment is complete.

BENDIX/KING**KCS 55/55A**

CAUTION:
INSTRUMENT AND GYRO REPAIR MUST BE ACCOMPLISHED BY A HONEYWELL APPROVED INSTRUMENT SERVICE CENTER. WARRANTY IS VALID ONLY WHEN THE DUST COVER SEAL IS IN CONTACT.

2.8.6 ALTERNATE METHOD OF COMPENSATION ADJUSTMENTS FOR KMT 112 AND KA 51/KA 51A

The small slaving indicator in the KA 51/KA 51A, although shielded, is still susceptible, to magnetic and electrical interference occurring in and around the aircraft instrument panel. This interference, depending upon the KA 51/KA 51A's location in the instrument panel, can cause an observable indicator needle offset in the compass system during power on and/or power off conditions. The following adjustment procedures should be used to align the compass system more accurately.

Remove the KA 51/KA 51A from its housing and connect a digital millivolt meter to the rear of the slaving indicator, black wire to the common and red wire to the positive connection of the millivolt meter.

A. KMT 112 Alignment

With the complete KCS 55/KCS 55A System operating and synchronized, position the aircraft on a compass rose and turn it to each of the four cardinal headings. Place the KA 51/KA 51A in the "Free Gyro" mode and zero the external millivolt meter with the manual slave buttons on the KA 51/KA 51A at each of these headings. Record the error, as a signed number, e.g. (-4), between the compass rose and heading on the KI 525/KI 525A. Add the errors algebraically and divide by four to obtain the index error. Loosen the mounting screws on the KMT 112 and rotate the unit an amount equal and opposite to the index error to cancel out the index error. Retighten the mounting screws.

B. KA 51/KA 51A Adjustment

With the complete KCS 55/KCS 55A System operating and the KA 51/KA 51A in the "Free Gyro" mode; position the aircraft on a compass rose and adjust the compensation as follows:

1. Place the aircraft on a North heading and center the compass card North under the lubber line with the manual slave buttons. Place a non-magnetic blade screwdriver in the N/S potentiometer on the KA 51/KA 51A and zero the external millivolt meter. (0VDC \pm 50mV)
2. Place the aircraft on an East heading and center the compass card East under the lubber line with the manual slave buttons. Place a non-magnetic blade screwdriver in the E/W potentiometer on the KA 51/KA 51A and zero the external millivolt meter. (0VDC \pm 50mV)
3. Place the aircraft on a South heading and center the compass card South under the lubber line with the manual slave buttons. Place a non-magnetic blade screwdriver in the N/S potentiometer on the KA 51/KA 51A and adjust the external millivolt meter for 1/2 of the existing meter readout.

BENDIX/KING**KCS 55/55A**

4. Place the aircraft on a West heading and center the compass card West under the lubber line with the manual slave buttons. Place a non-magnetic blade screwdriver in the E/W potentiometer on the KA 51/KA 51A and adjust the external millivolt meter for 1/2 of the existing meter readout.

As a final check of the KCS 55/KCS 55A System, the aircraft should be positioned on the compass rose and turned to each of the four cardinal headings while the KCS 55/KCS 55A System in the "Slaved Gyro" mode. All readings should be within $\pm 2^\circ$ of those on the compass rose.

Next with the aircraft on a North heading and the KCS 55/KCS 55A System turned off but all other aircraft systems still on, adjust the KA 51/KA 51A indicator movement via the adjustment in the upper rear of the indicator to zero the slaving indicator. The KA 51/KA 51A can now be reassembled in the aircraft; the alignment is complete.

2.8.7 KA 52 AND KA 57

NOTE:

The autopilot operation must be confirmed as correct before the following adjustments are attempted. If possible, check the autopilot components alignment on the bench.

Take off the KA 52/57 dust cover by removing the two screws on the side of the unit. The HDG and CRS potentiometers at the left rear of the printed circuit board (viewing the board from the connector end) provide the gain adjustments for the course and heading modes of operation. The following is a procedure for setting the gains for the Mitchell Century II and III autopilots. The variations in the procedure for setting the gains in other autopilots are given at the end of each section.

NOTE:

On the KA 57 R108, the HDG select gain adjust is located near the outside edge of the board. R109, the CRS datum gain adjust is located toward the center of the board. On KA 52's, the adjustments are marked accordingly.

HDG: With the autopilot off, manually adjust the attitude gyro for $+10^\circ$ of offset (the attitude gyro artificial horizon rotated 10° counterclockwise from its 0° position). Turn on the autopilot and set it in the Heading mode (Radio Coupler selector switch set to Heading) and position the KI 525 Heading Select Marker for $+10^\circ$ of offset (Marker 10° clockwise from lubber line). Adjust the HDG potentiometer until there is no movement of the control wheel. Check the gain setting by repositioning the control wheel to the center of its range and observing that there is no movement either clockwise or counterclockwise.

Next, turn off the autopilot and reposition the attitude gyro for -10° of offset (the attitude gyro artificial horizon rotated 10° clockwise from its 0° position). Turn on the autopilot and slew the Heading Select Marker to -10° (Marker 10° counterclockwise from the lubber line).

BENDIX/KING**KCS 55/55A**

The control wheel should stop moving when the marker reaches -10° . Center the control wheel to midrange and observe there is no movement either clockwise or counterclockwise.

The absolute value of the null position clockwise and counterclockwise from the lubber line (nominally $\pm 10^{\circ}$) should be within two degrees of each other.

For Cessna Autopilots, the procedure for setting the HDG gain is the same as that described above except for the controller settings which are as follows:

Pull-Turn Control Knob - Pushed in

Intercept - TRK-HDG - HDG

CRS: Set the attitude gyro for 0° of offset, turn on the autopilot and set it for the Course Mode (Radio Coupler Selector switch set on OMNI). Acquire a VOR station on the appropriate radio and when the KI 525/525A NAV flag disappears center the Course pointer and deviation bar under the lubber line. Next, rotate the Course pointer to $+45^{\circ}$ (clockwise from the lubber line by 45°) and adjust the CRS potentiometer until there is no movement of the control wheel. Reposition the control wheel to the center of its range and observe there is no movement of the control wheel.

Next, check the setting of the CRS gain by slewing the Course pointer to -45° (counterclockwise from the lubber line by 45°) the control wheel should stop moving when the Course pointer reaches -45° . The absolute value of the two intercepts (nominally $\pm 45^{\circ}$) should be within 5° of each other.

For the Cessna Autopilots, the procedure for setting the CRS gain is the same as that described above except for the Controller Settings which are as follows:

Pull - Turn Control Knob - Pushed in

Intercept - TRK - HDG - Intercept

To check the Mitchell Century II & III Localizer operation, set the appropriate radio to a Localizer frequency and the Radio Coupler selector switch to LOC. Rotate the KI 525/525A Course pointer clockwise and note that the control wheel also rotates clockwise. Change the Radio Coupler selector switch to LOC REV, rotate the Course pointer clockwise and observe that the control wheel rotates in the opposite direction, counterclockwise. The back course approach is flown with the course pointer set to the front course to give proper deviation bar steering to the pilot.

NOTE:

When the KA 57 is coupled to a Mitchell Century II or III and the system is operated incorrectly by selecting a Radio Coupler LOC mode with a VOR frequency selected on the Radio or a VOR Omni mode on the Radio Coupler with an ILS frequency on the radio, the KA 57 Course Datum output will be 180 degrees out of phase.

BENDIX/KING**KCS 55/55A****2.9 AVAILABILITY OF 400 HZ POWER FROM THE KG 102/KG 102A**

This section contains information pertaining to 400 Hz. power requirements and the use of the KG 102/102A as a source. Refer to figure 2-28 for additional information.

If a KI 229, KGR 356, GC 381, or KNI 582 is installed with a KCS 55A Compass System, 26 V, 400 Hz. power is needed to excite the heading bootstrap in the KI 525/525A and the compass H and C inputs of the KI 229, KGR 356, GC 381, or KNI 582. In some cases, the KG 102/102A can supply the necessary 400 Hz. power and eliminate the requirement for an external inverter. If the following conditions are met, the KG 102/102A can supply adequate 26 V, 400 Hz. power

1. Except as noted below and in figure 2-28, the excitation of the KI 525/525A heading bootstrap rotor H and C will be the only load on the KG 102/102A 26 VAC output (P1021, pins p and t).
2. The compass heading X, Y, and Z inputs of the KI 229, KGR 356, GC 381, or KNI 582 will be the only load on the heading bootstrap output.
3. No additional loads, such as the course datum synchro in a NAV 2 indicator (for NAV1/NAV2 autopilot transfer), will be connected to the KG 102/102A 26 VAC output (P1021, pins p and t).
4. Some Honeywell Flight Control Systems incorporate a KRG 331 Rate Gyro. These units are typically shown powered off of the KG 102A. The KG 102A will not simultaneously supply a KRG 331 and a KI 229 or KNI 582.

In addition, radar graphics requiring 400 Hz. power, such as the GC 381A or KRG 356, may be installed utilizing the output of the KG 102/102A. Since these units only require .01 MVA of power, they may be installed in addition to a KI 229 or KNI 582 without requiring an external inverter. Also, the KG 102A will supply enough power for a KRG 331 and KRG 356 or GC 381A.

NOTE:

The KG 102/102A has a 5 VA maximum of 26 V, 400 Hz power available for all uses. If more than 5 VA is required, an external 400 Hz. inverter will be necessary.

CAUTION:

If the 5 VA maximum is exceeded, severe damage will result to the power supply causing catastrophic failure of the compass system.

CAUTION:

Two (2) 400 Hz. outputs cannot be paralleled. An inverter, when required, must be large enough to handle the total AC load.

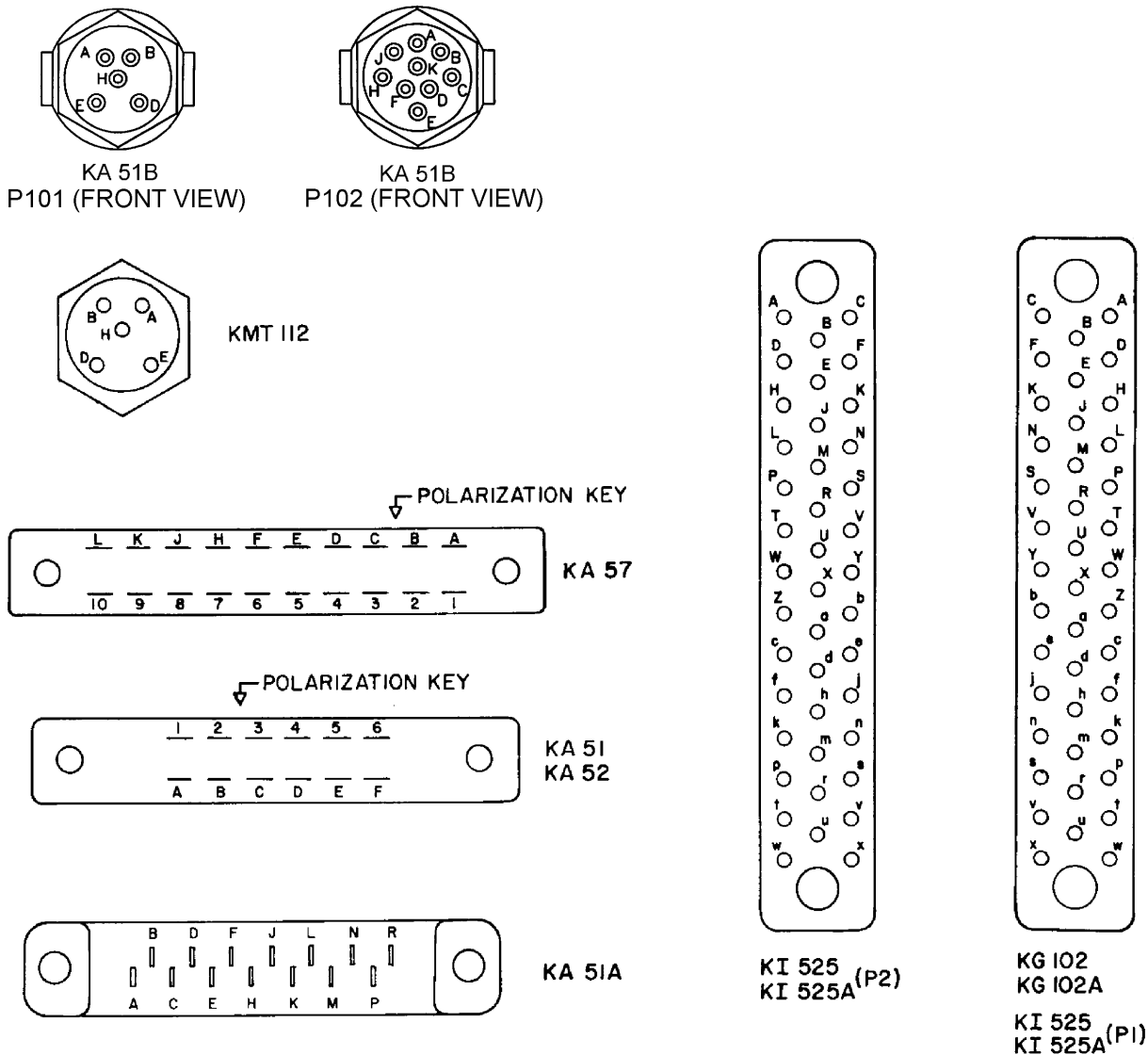
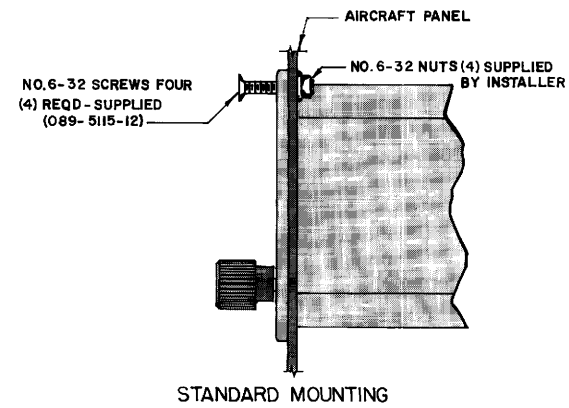
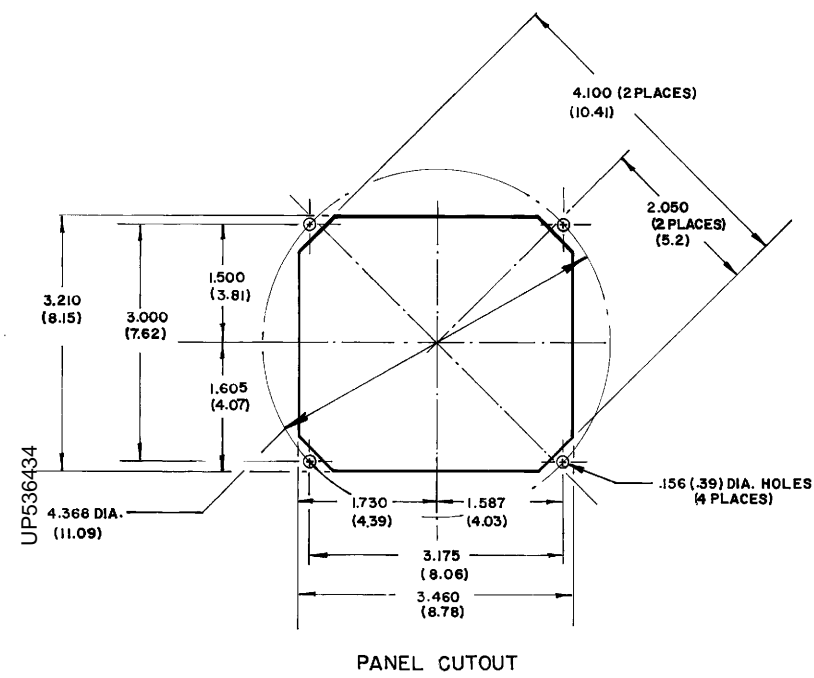
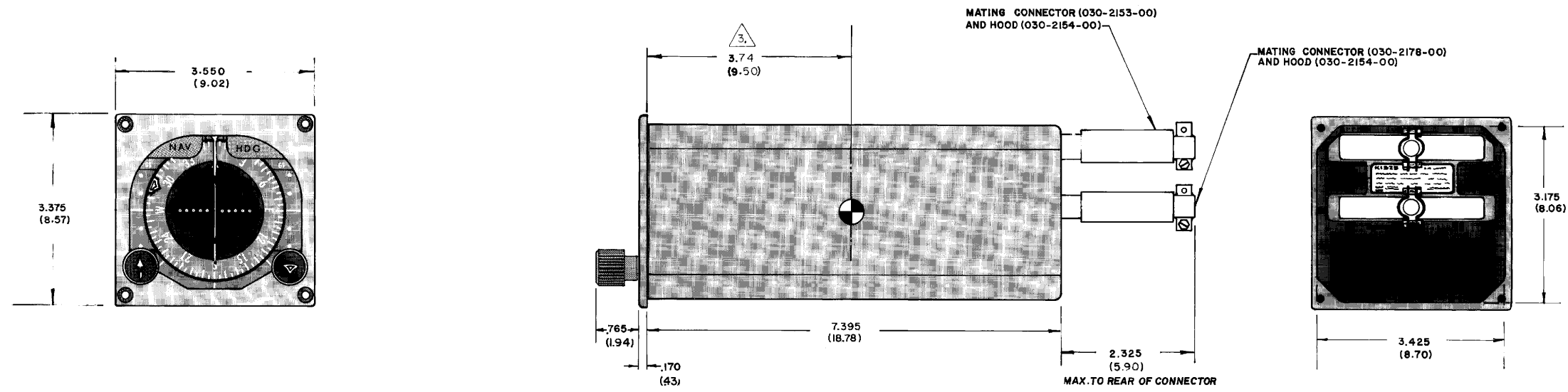

FIGURE 2-1 PIN LOCATIONS
(Viewed From REAR of Mating Connectors Except Where Noted)



- NOTES:
1. DIMENSIONS IN () ARE IN CENTIMETERS.
 2. WEIGHT OF UNIT: 3.38 LB (1.53 Kg). WEIGHT OF INSTALLATION HARDWARE AND MATING CONNECTORS: 0.20 LB (.09 Kg).
 3. CENTER OF GRAVITY IS FOR UNIT ONLY WITHOUT INSTALLATION HARDWARE OR MATING CONNECTORS.

FIGURE 2-2 KI 525/525A INSTALLATION DRAWING
(Dwg. No. 155-05117-0000, R-AA)

UP536434

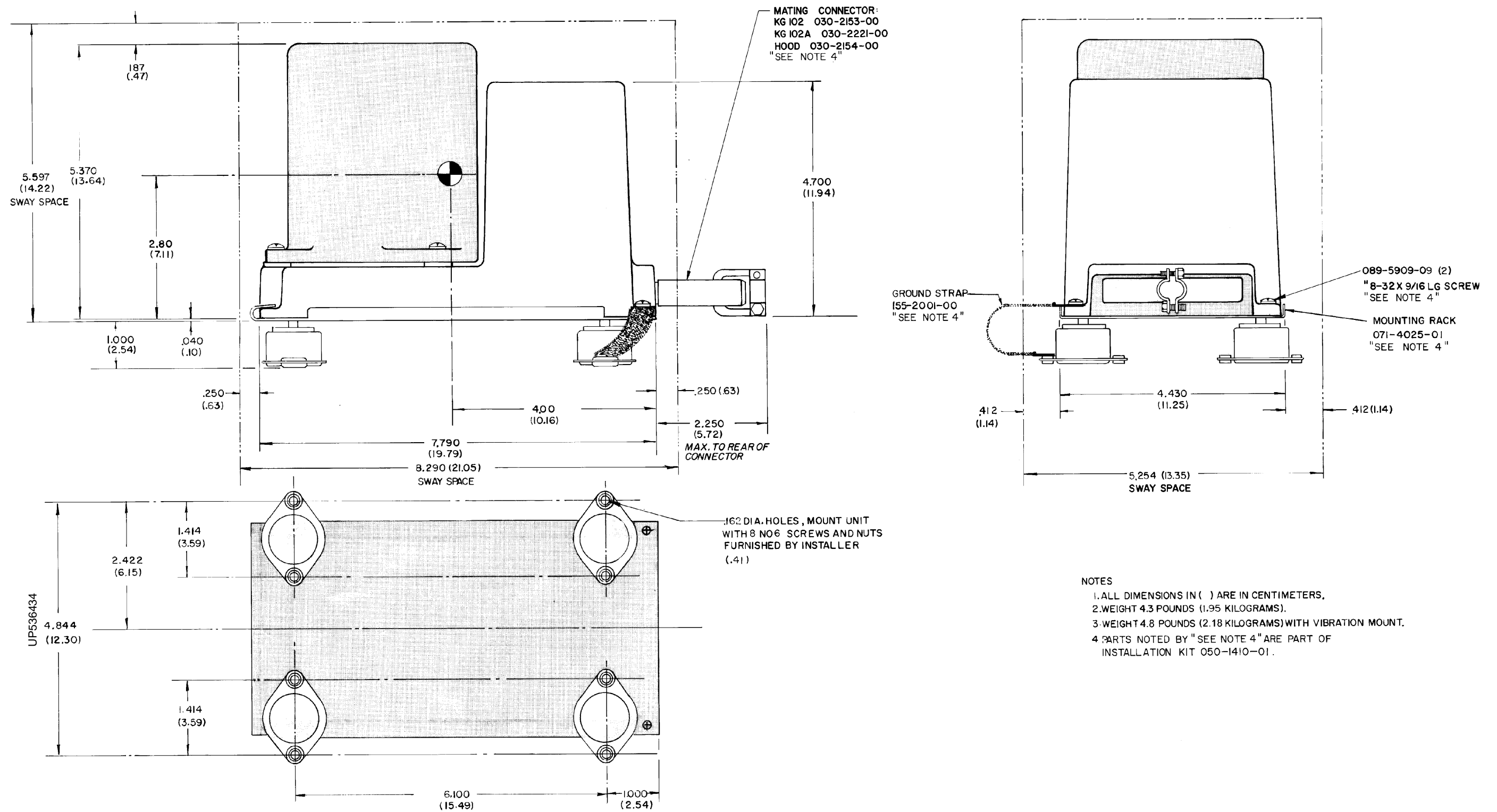

FIGURE 2-3 KG 102/102A INSTALLATION DRAWING
 (Dwg. No. 155-05118-0000, R-AA)

UP536434

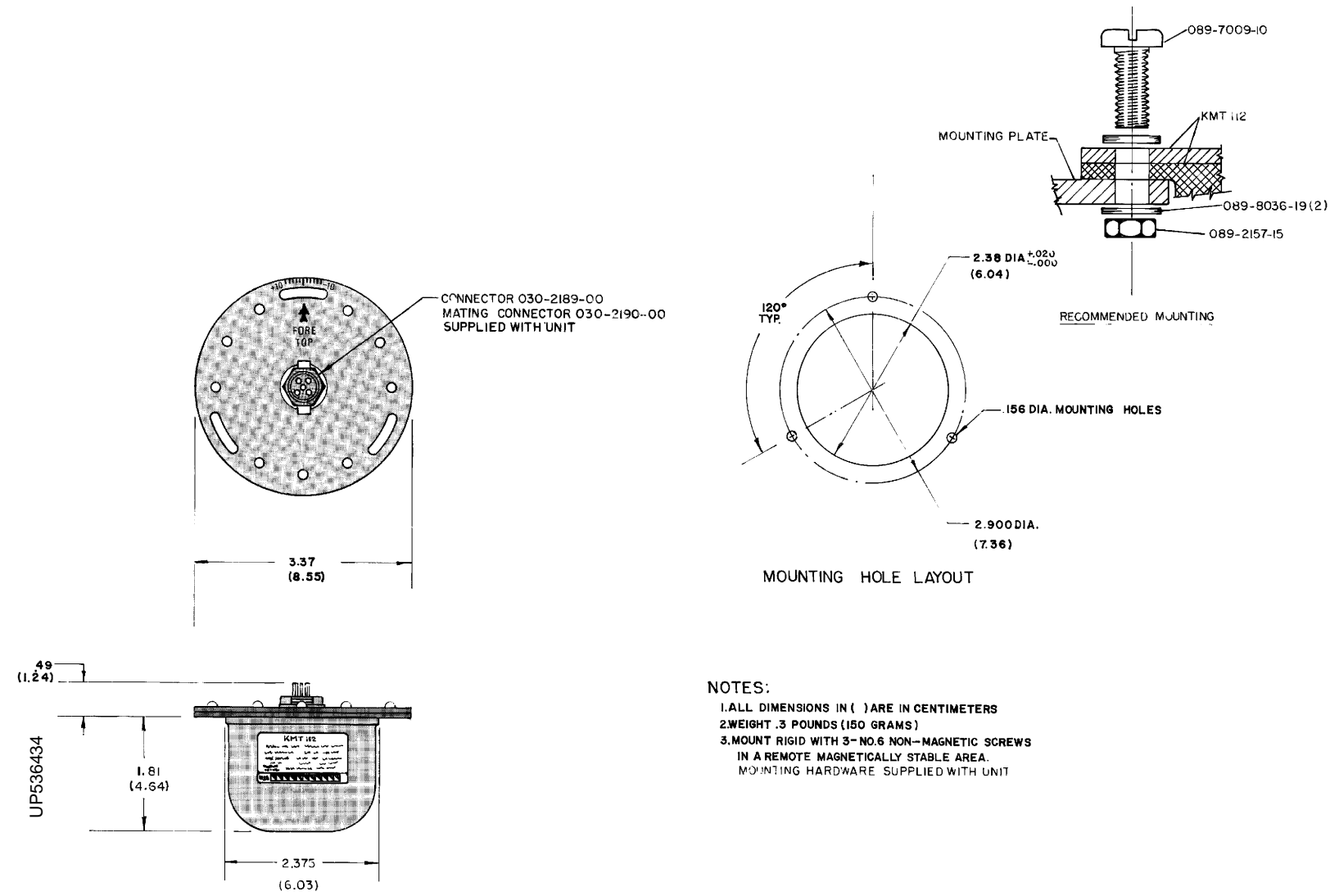

FIGURE 2-4 KMT 112 INSTALLATION DRAWING
(Dwg. No. 155-05130-0000, R-1)

UP536434

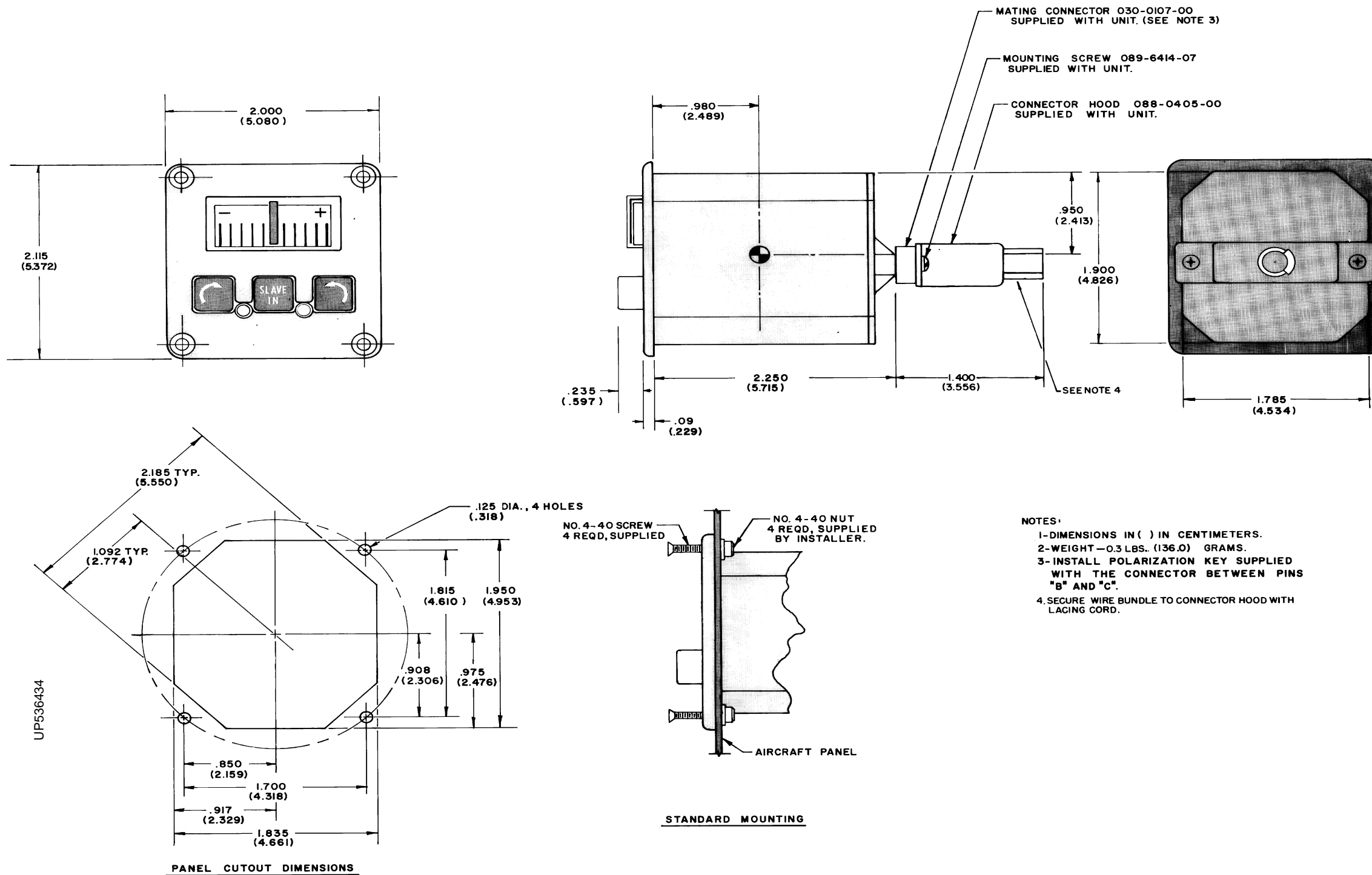

FIGURE 2-5 KA 51 INSTALLATION DRAWING
(Dwg. No. 155-05144-0000, R-1)

UP536434

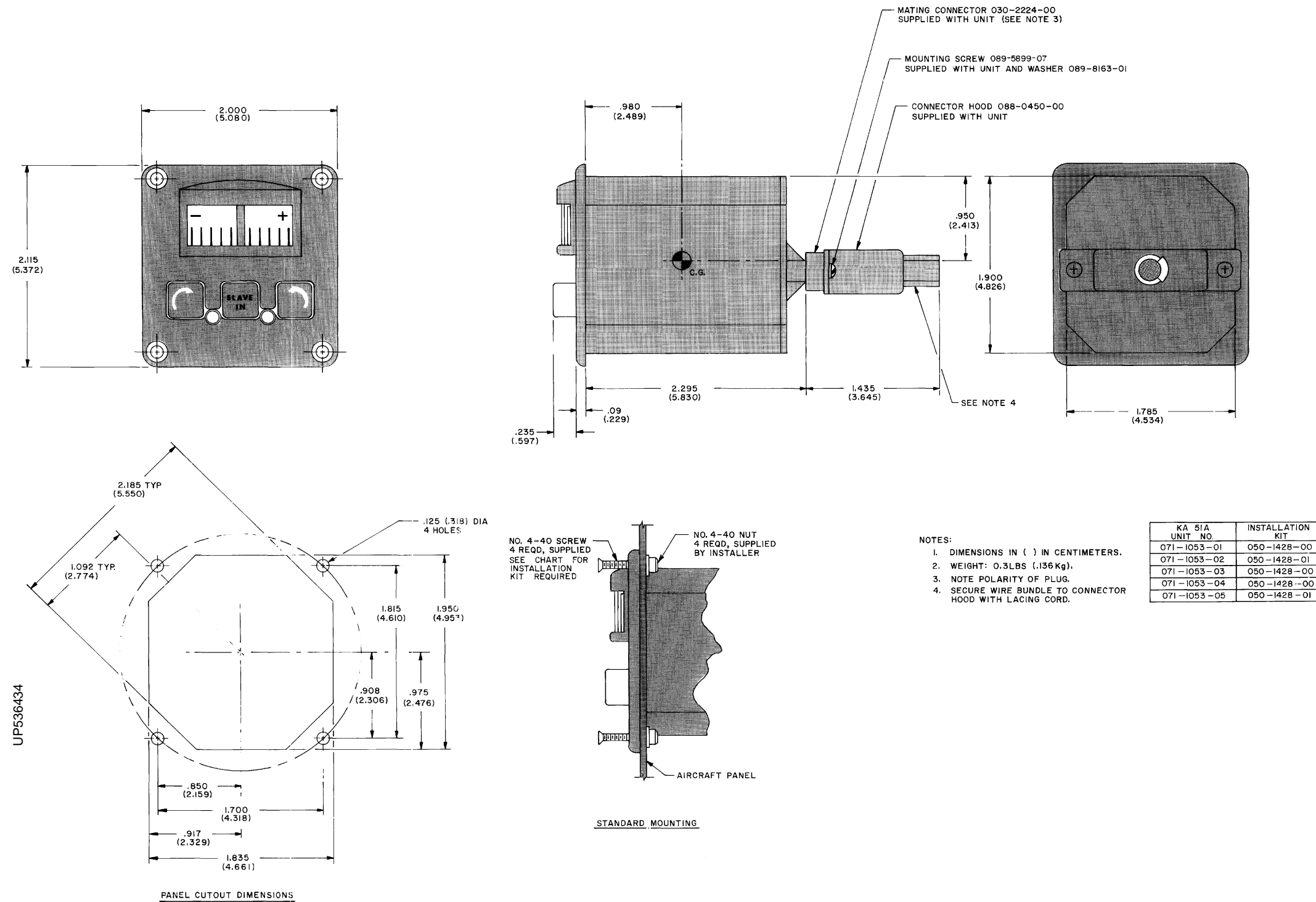
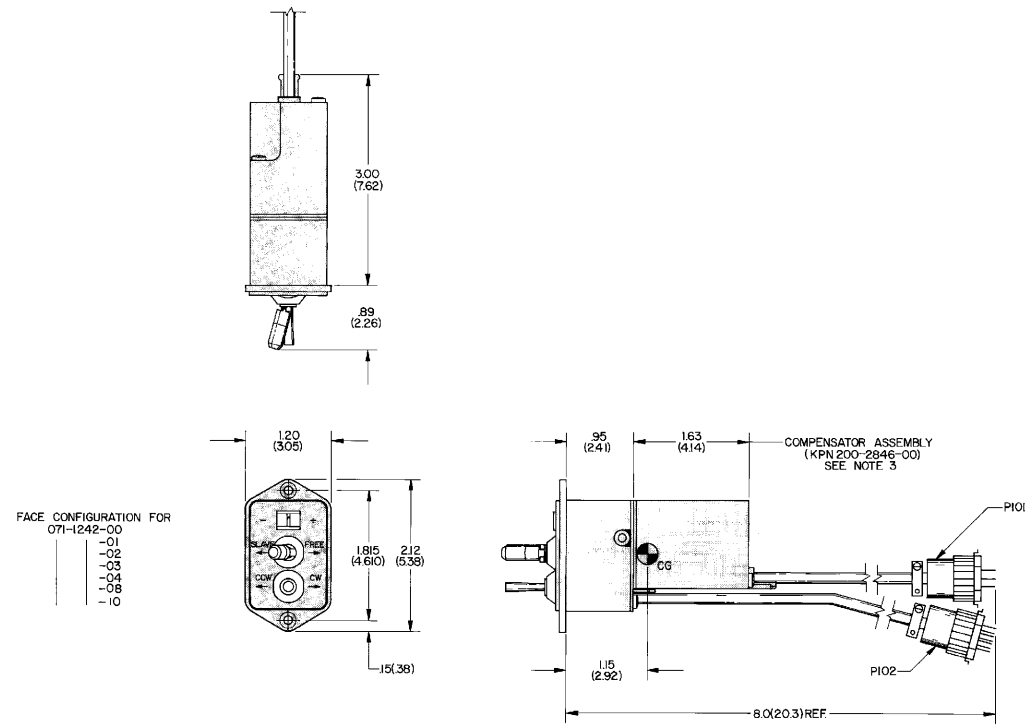

FIGURE 2-6 KA 51A INSTALLATION DRAWING
(Dwg. No. 155-05144-0001, R-3)

UP536434

-OPTIONS-



-FACE OPTION-



FACE CONFIGURATION FOR 071-1242-05, -06, -07, 09-11, & -12

-REMOTE MOUNTED COMPENSATOR OPTION-

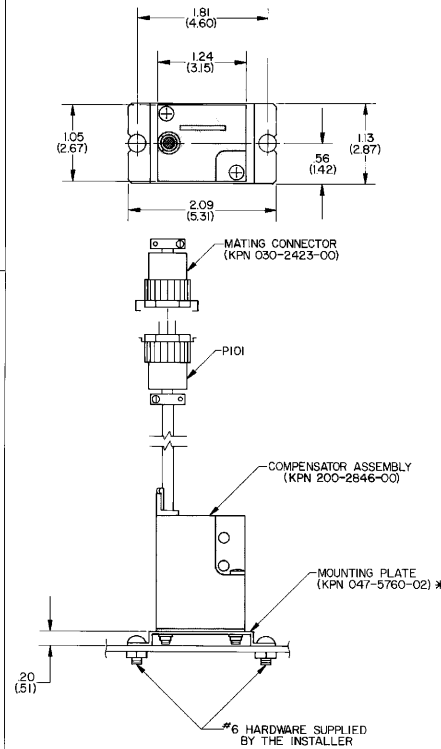

- NOTES:
1. ALL DIMENSIONS IN () ARE IN CENTIMETERS.
 2. WEIGHT: 0.2LBS (0.91Kg).
 3. THE COMPENSATOR ASSEMBLY MAY BE LOCATED REMOTELY.
 4. PARTS MARKED WITH * ARE INCLUDED IN THE 050-1928-00 INSTALLATION KIT.
 5. A COMPENSATOR KIT IS AVAILABLE FOR INSTALLATIONS WHERE THE INSTALLER WISHES TO USE A DIFFERENT SWITCH/METER ARRANGEMENT. THE COMPENSATOR KIT PART NUMBER IS 050-1928-01 & CONTAINS THE FOLLOWING ITEMS:
 KPN 200-2846-00 COMPENSATOR ASSEMBLY
 KPN 030-2423-00 COMPENSATOR MATING CONNECTOR
 KPN 047-5760-02 MOUNTING PLATE
 6. PANEL CUTOUT TOOLS:
 DECAL NO. 057-2105-17
 FILE TEMPLATE NO. 071-6039-17

UP536434

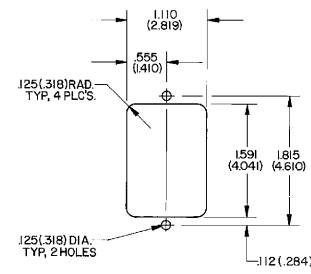

-PANEL CUTOUT DIMENSIONS-

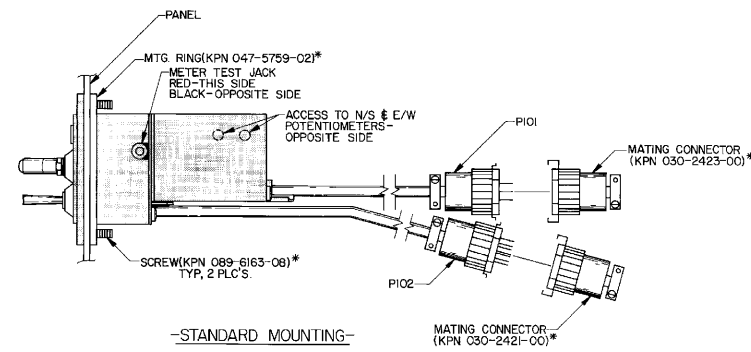

-STANDARD MOUNTING-

FIGURE 2-7 KA 51B INSTALLATION DRAWING (Dwg. No. 155-05371-0000, R-4)

UP536434

BENDIX/KING

KCS 55/55A

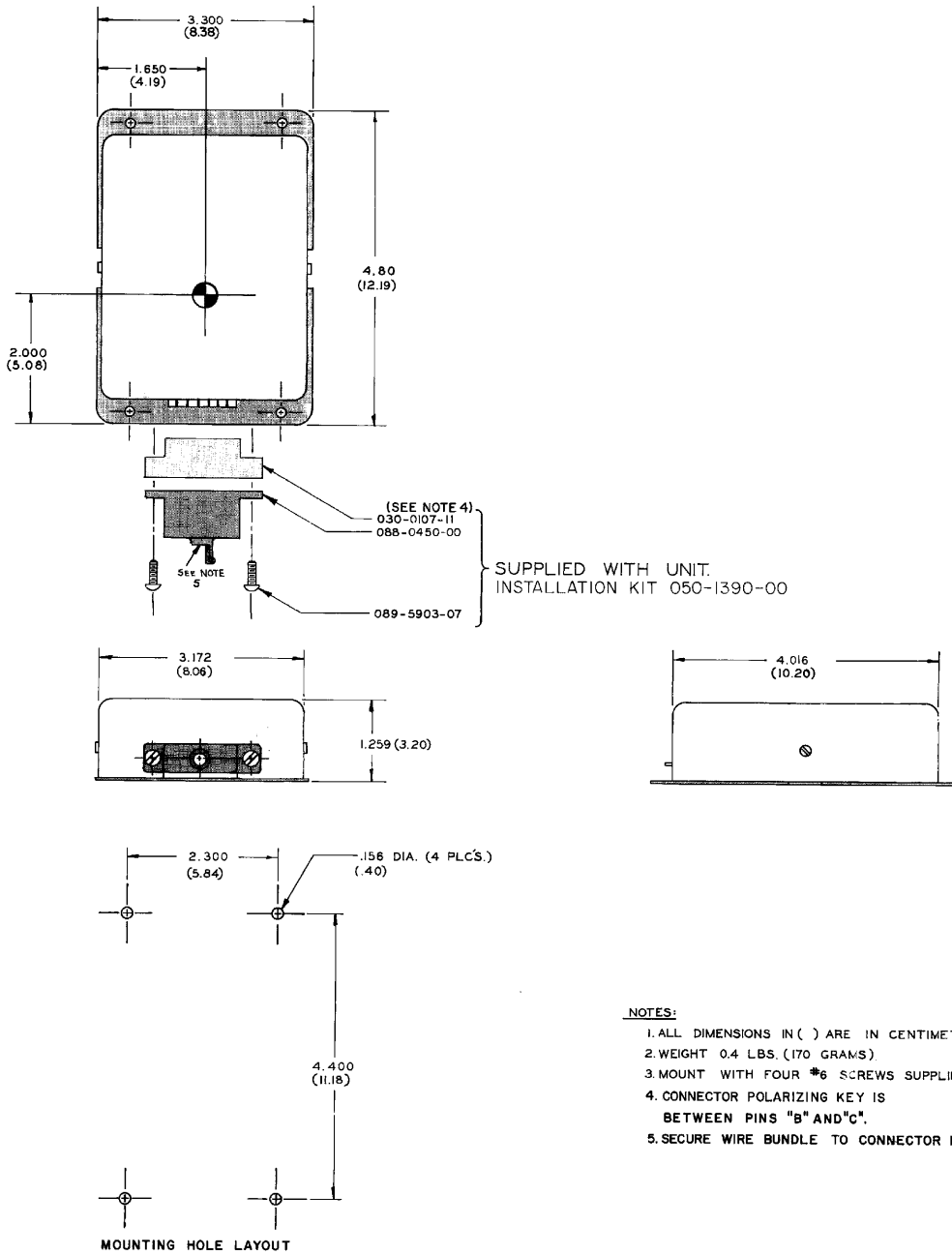

NOTES:

1. ALL DIMENSIONS IN () ARE IN CENTIMETERS.
2. WEIGHT 0.4 LBS. (170 GRAMS)
3. MOUNT WITH FOUR #6 SCREWS SUPPLIED BY INSTALLER.
4. CONNECTOR POLARIZING KEY IS BETWEEN PINS "B" AND "C".
5. SECURE WIRE BUNDLE TO CONNECTOR HOOD WITH LACING CORD.

**FIGURE 2-8 KA 52 INSTALLATION DRAWING
(Dwg. No. 155-05143-0000, R-2)**

BENDIX/KING

KCS 55/55A

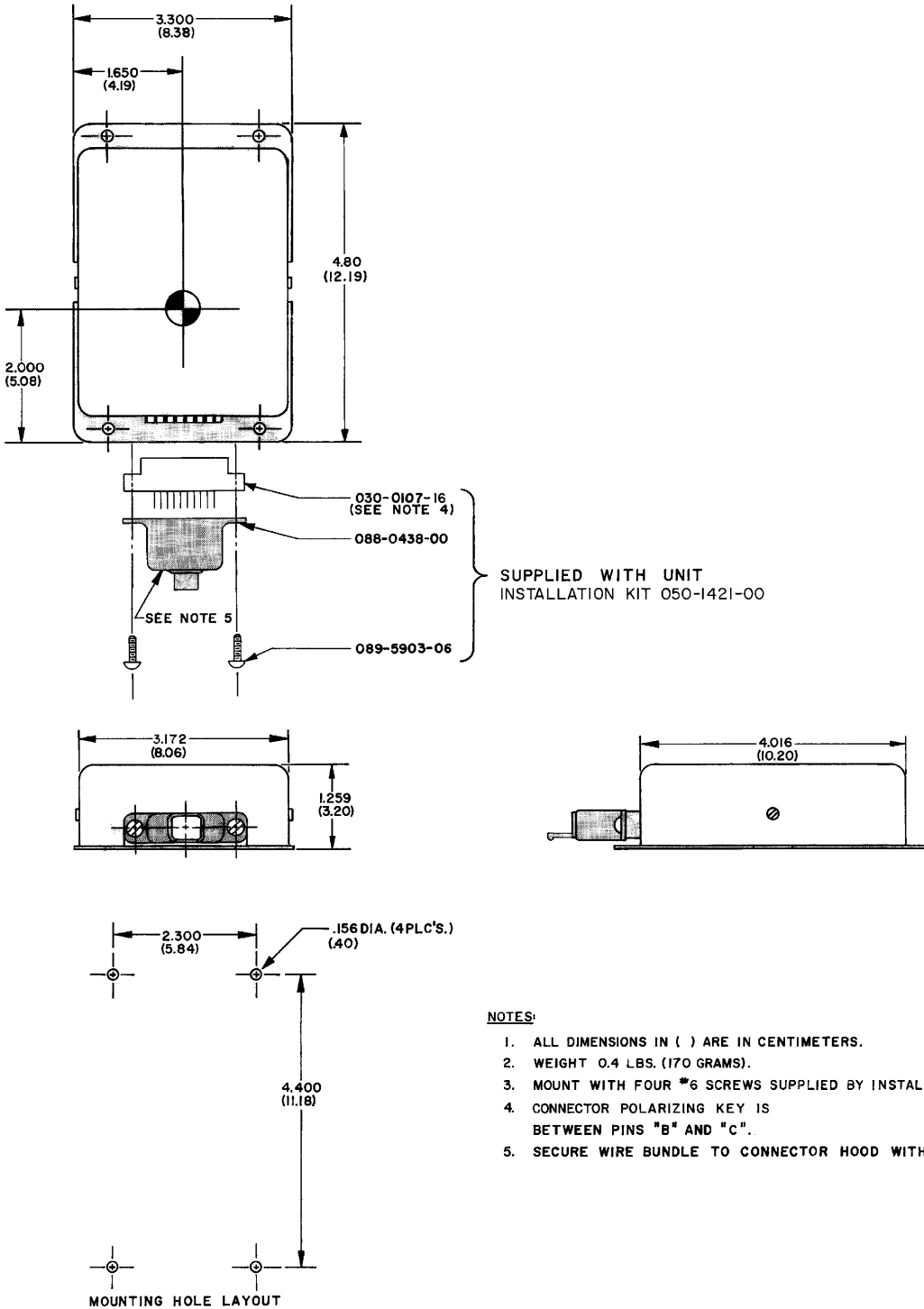

NOTES:

1. ALL DIMENSIONS IN () ARE IN CENTIMETERS.
2. WEIGHT 0.4 LBS. (170 GRAMS).
3. MOUNT WITH FOUR #6 SCREWS SUPPLIED BY INSTALLER.
4. CONNECTOR POLARIZING KEY IS BETWEEN PINS "B" AND "C".
5. SECURE WIRE BUNDLE TO CONNECTOR HOOD WITH LACING CORD.

**FIGURE 2-9 KA 57 INSTALLATION DRAWING
(Dwg. No. 155-05165-0000, R-1)**

UP536434

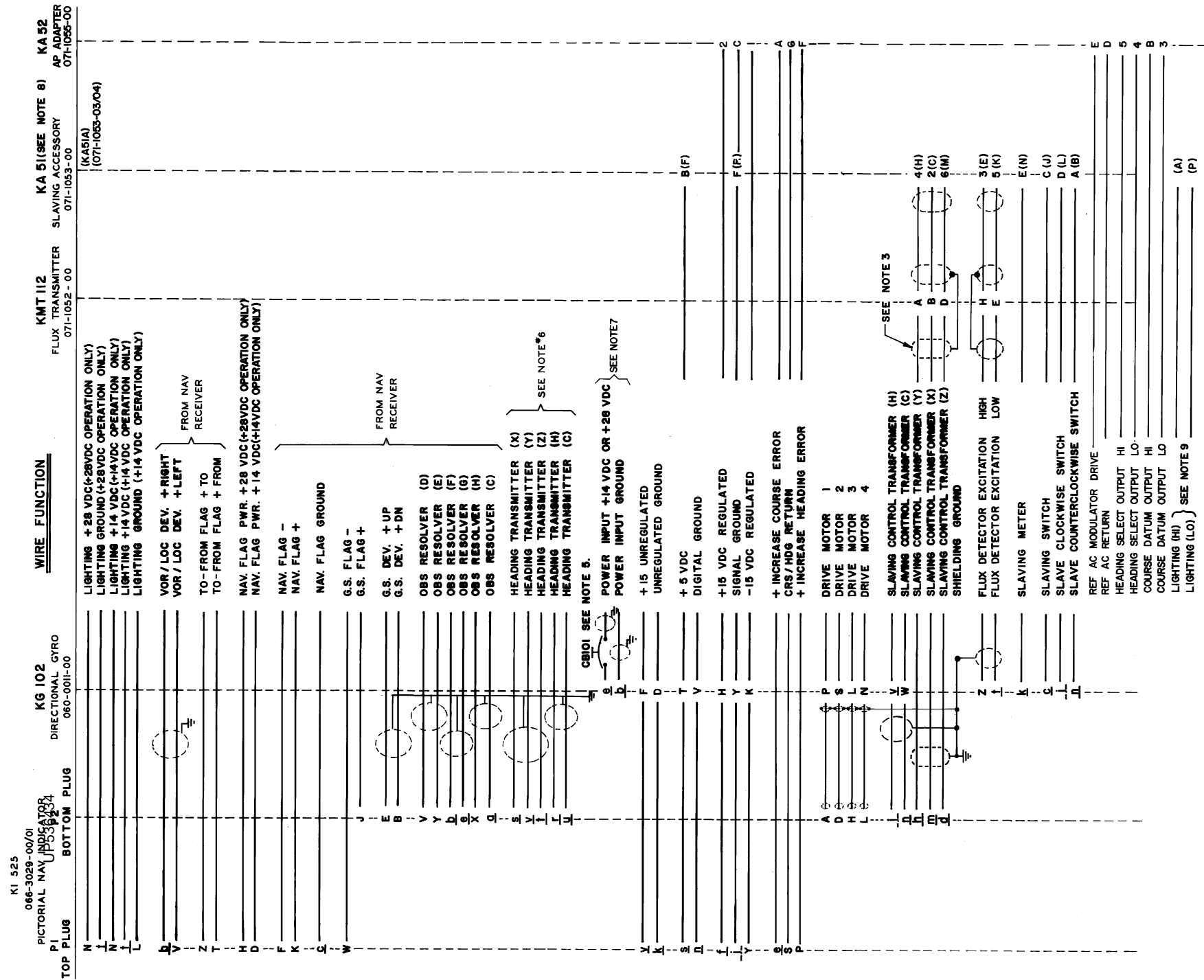

- NOTES**
- UNLESS NOTED ALL WIRES TO BE #22 AWG MINIMUM.
 - UNLESS NOTED ALL SYSTEM GROUNDS ARE AIRFRAME GROUNDS.
 - INSULATED SHIELD.
 - () DENOTES ARINC NOMENCLATURE.
 - 2 AMPS FOR 28 VDC SYSTEM.
 - 5 AMPS FOR 14 VDC SYSTEM.
 - THESE OUTPUTS ARE PROVIDED ON THE 066-3029-01 INDICATOR ONLY.
 - WHEN OPERATING WITH 14VDC SYSTEM LINES g AND h MUST BE 18 GA. WIRE.
 - KASIA MAY BE INSTALLED. PIN NUMBERS IN () REFER TO CORRESPONDING KI 525-KG 102 TO KASIA CONNECTIONS
 - KASIA LIGHTING: 071-1053-03 — +14VDC
071-1053-04 — +28VDC

FIGURE 2-10 KCS 55 SILVER CROWN COMPASS SYSTEM INTERCONNECT DIAGRAM (Dwg. No. 155-01147-0000, R-8)

UP536434

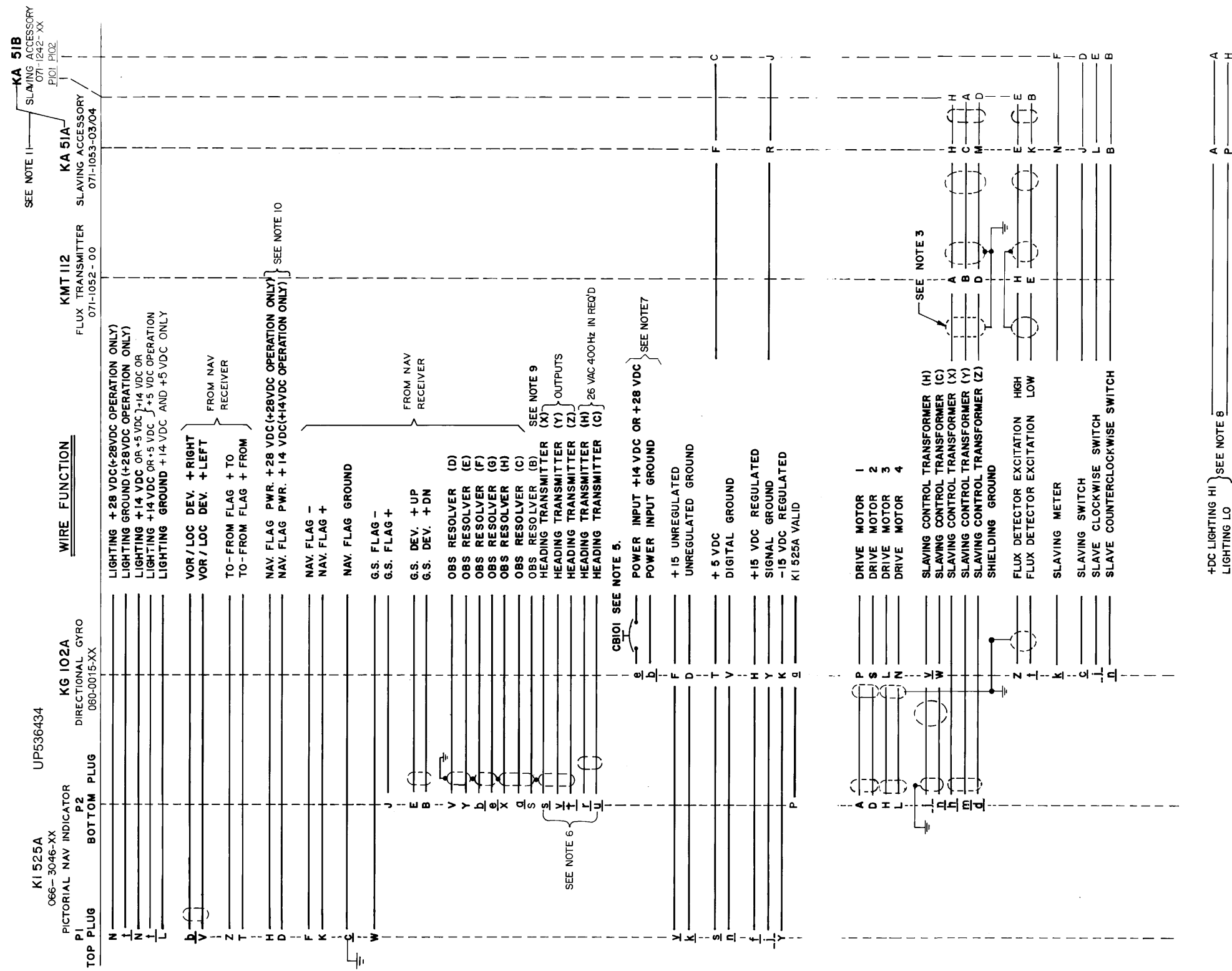
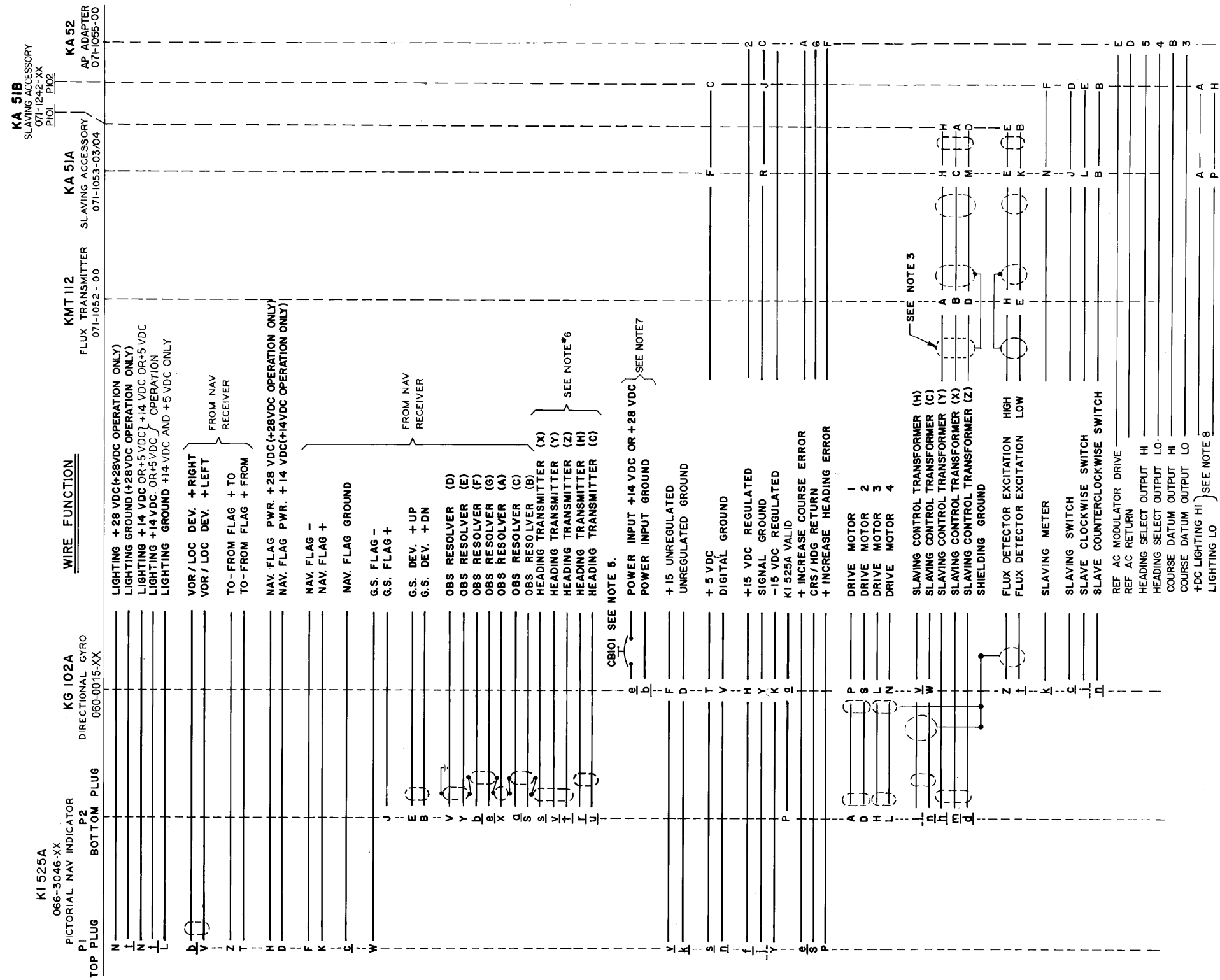

FIGURE 2-11 KCS 55A SILVER CROWN COMPASS SYSTEM (30Hz OBS RESOLVER) INTERCONNECT DIAGRAM (Dwg. No. 155-01147-0001, R-AB)

UP536434

UP536434



NOTES

1. UNLESS NOTED ALL WIRES TO BE #22 AWG MINIMUM.
2. UNLESS NOTED ALL SYSTEM GROUNDS ARE AIRFRAME GROUNDS.
3. INSULATED SHIELD.
4. () DENOTES ARINC NOMENCLATURE.
5. 2 AMPS FOR 28 VDC SYSTEM.
5 AMPS FOR 14 VDC SYSTEM.
6. THESE OUTPUTS ARE PROVIDED ON THE 066-3046-01/03/05/07/08/09/10/11/12/13 INDICATORS ONLY.
7. WHEN OPERATING WITH 14VDC SYSTEM LINES a AND b MUST BE 18 GA. WIRE.
8. KA 51A (071-1053-03) +14V LIGHTING
(071-1053-04) +28V LIGHTING
KA 51B (071-1242-00, 05) +14V LIGHTING
(071-1242-01, 02, 04, 06) +28V LIGHTING
(071-1242-03) +5V LIGHTING

FIGURE 2-12 KCS 55A SILVER CROWN COMPASS SYSTEM (400HZ OBS RESOLVER) INTERCONNECT DIAGRAM (Dwg. No. 155-01147-0002, R-AB)

UP536434

BENDIX/KING

KCS 55/55A

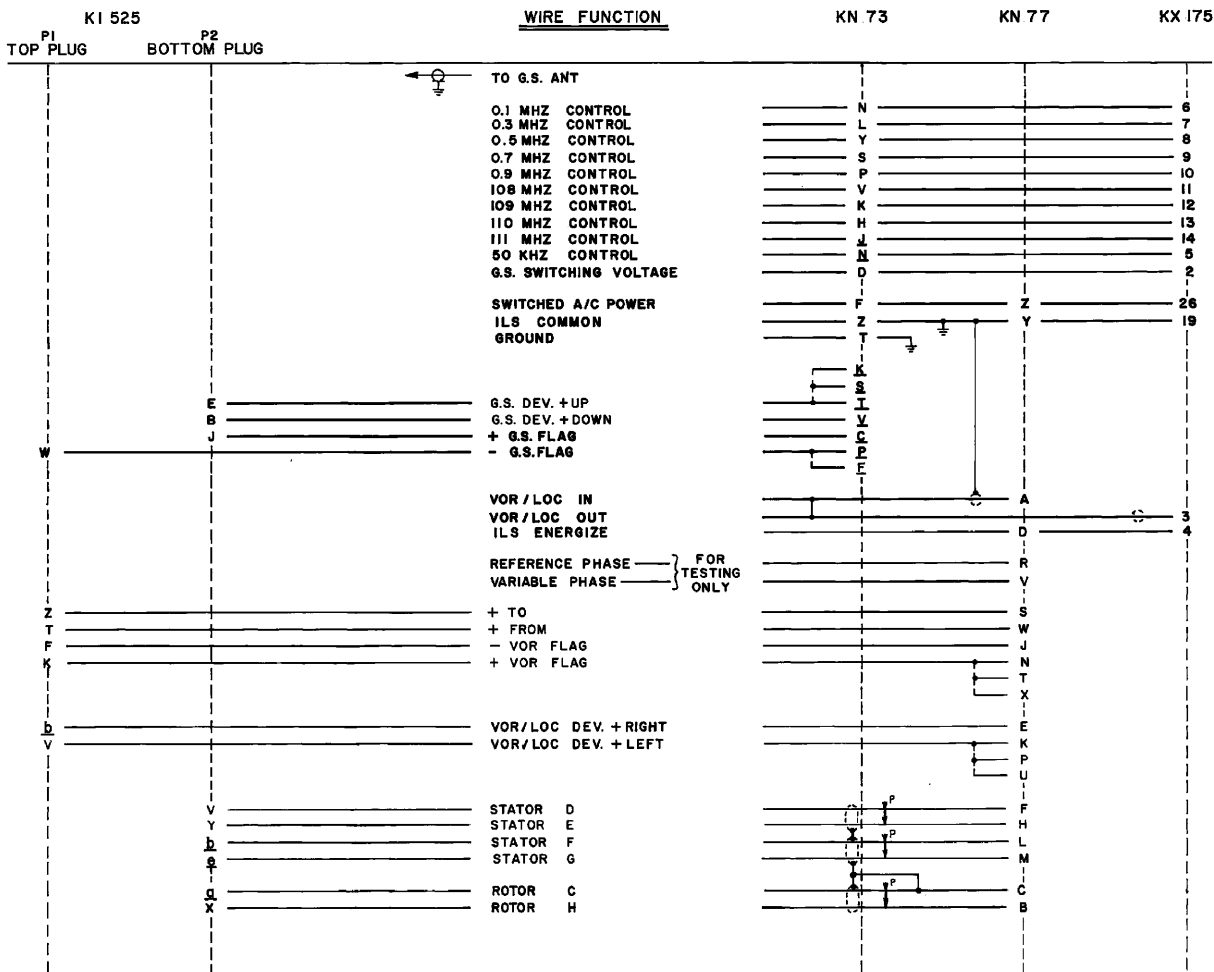

FIGURE 2-13 KX 175/KN 73/KN 77/KI 525/525A INTERCONNECT DIAGRAM (Dwg. No. 155-01148-0000, R-3)

BENDIX/KING

KCS 55/55A

THIS PAGE IS RESERVED

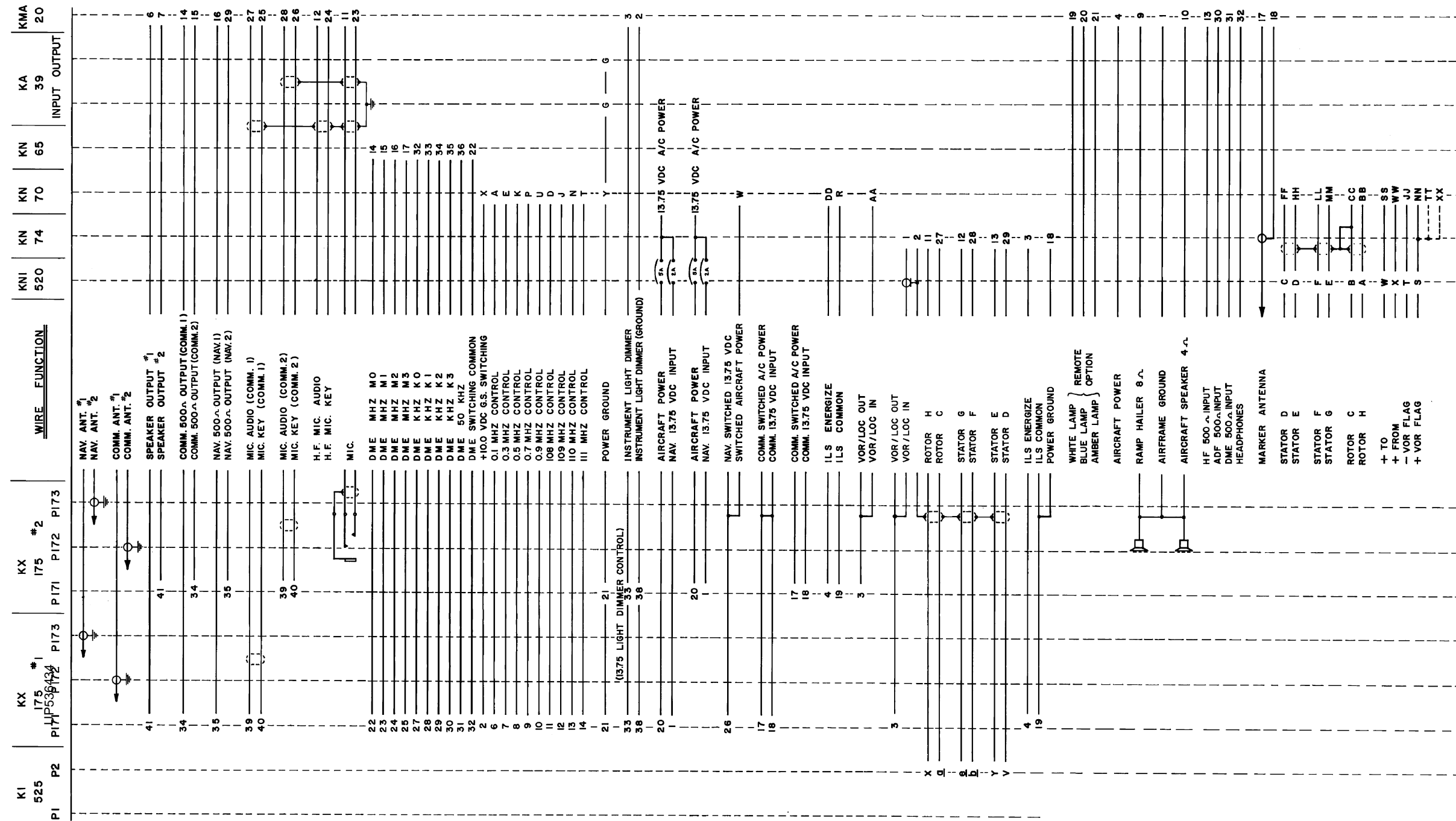
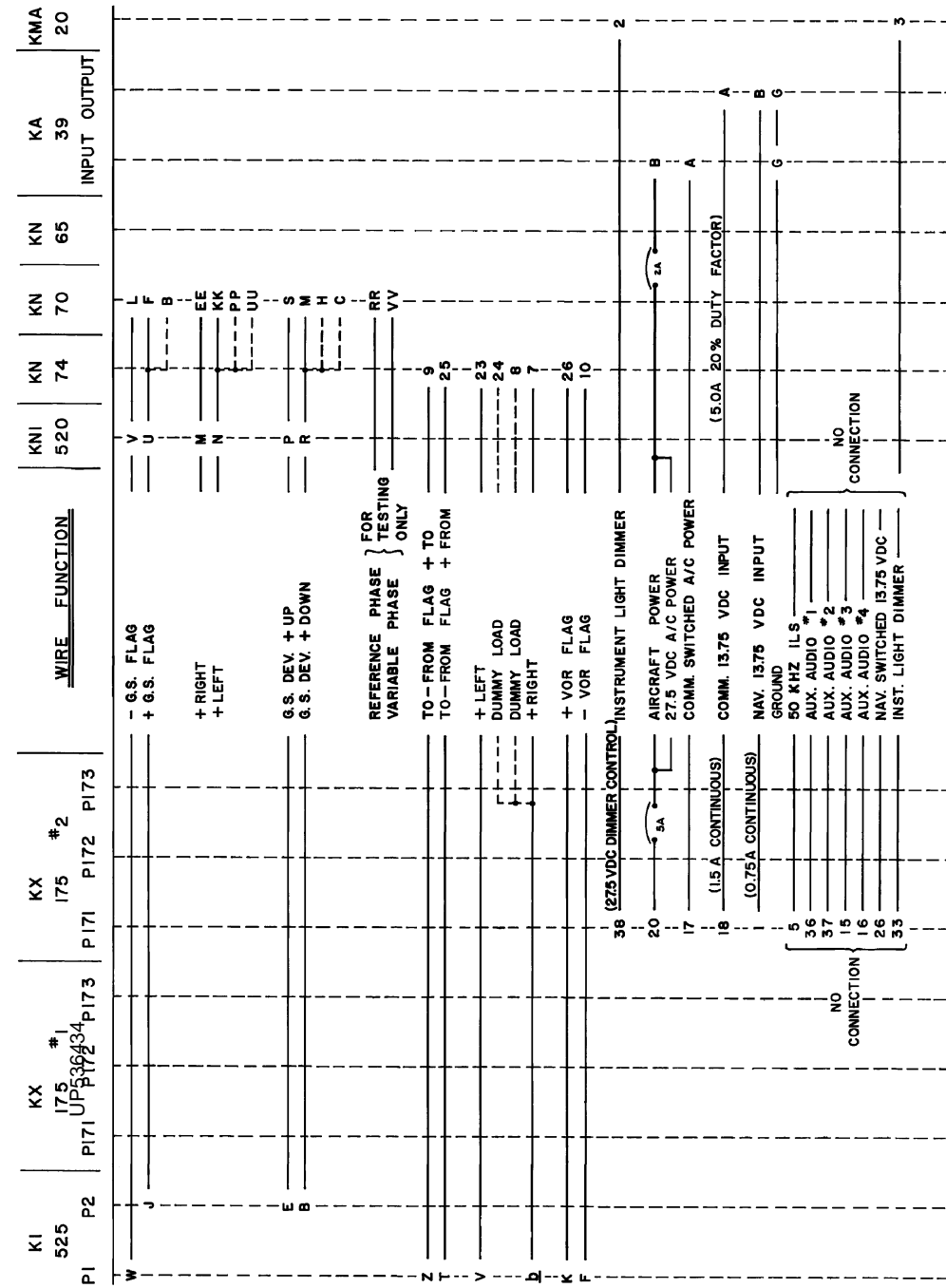

FIGURE 2-14 COMPLETE SILVER CROWN SYSTEM INTERCONNECT DIAGRAM
(Dwg. No. 155-01149-0000, R-0, Sheet 1 of 2)

UP536434



- NOTES:
- UNLESS NOTED, ALL WIRES 24 AWG MINIMUM.
 - ALL ANTENNA COAX IS RG8BAYU.
 - UNLESS OTHERWISE SPECIFIED, ALL SYSTEM GROUNDS ARE AIRFRAME GROUNDS.
 - THE KA47 MAY BE USED TO CONVERT KX175 DME SWITCHING OUTPUT TO CHANNEL 2 OUT OF 5 CODE DME'S.
 - KN70 JUMPER PINS AS INDICATED FOR REQUIRED NUMBER OF EXTERNAL LOADS.

- POWER BUSS CIRCUIT BREAKERS ARE TO BE MOUNTED IN THE AIRCRAFT BREAKER PANEL OR INSTRUMENT PANEL SUCH THAT THEY WILL BE ACCESSIBLE IN FLIGHT AND SAFE FROM PHYSICAL DAMAGE.
- KN 74 - FOR ONE INDICATOR JUMPER PINS 7, 8 & 24.
FOR THREE INDICATORS NO JUMPER REQUIRED.
- KN65 DME INDICATOR (KI265) NOT SHOWN.
- RAMP HALLER AND AIRCRAFT SPEAKER RETURN LEADS SHOULD BE CONNECTED TO PIN 1 AT KMA 20.
- EXTERNAL SWITCHING CAPABILITY: COMM - PIN 17 - NONE
NAV. - PIN 26 - 300 MA.

FIGURE 2-14 COMPLETE SILVER CROWN SYSTEM INTERCONNECT DIAGRAM
(Dwg. No. 155-01149-0000, R-0, Sheet 2 of 2)

UP536434

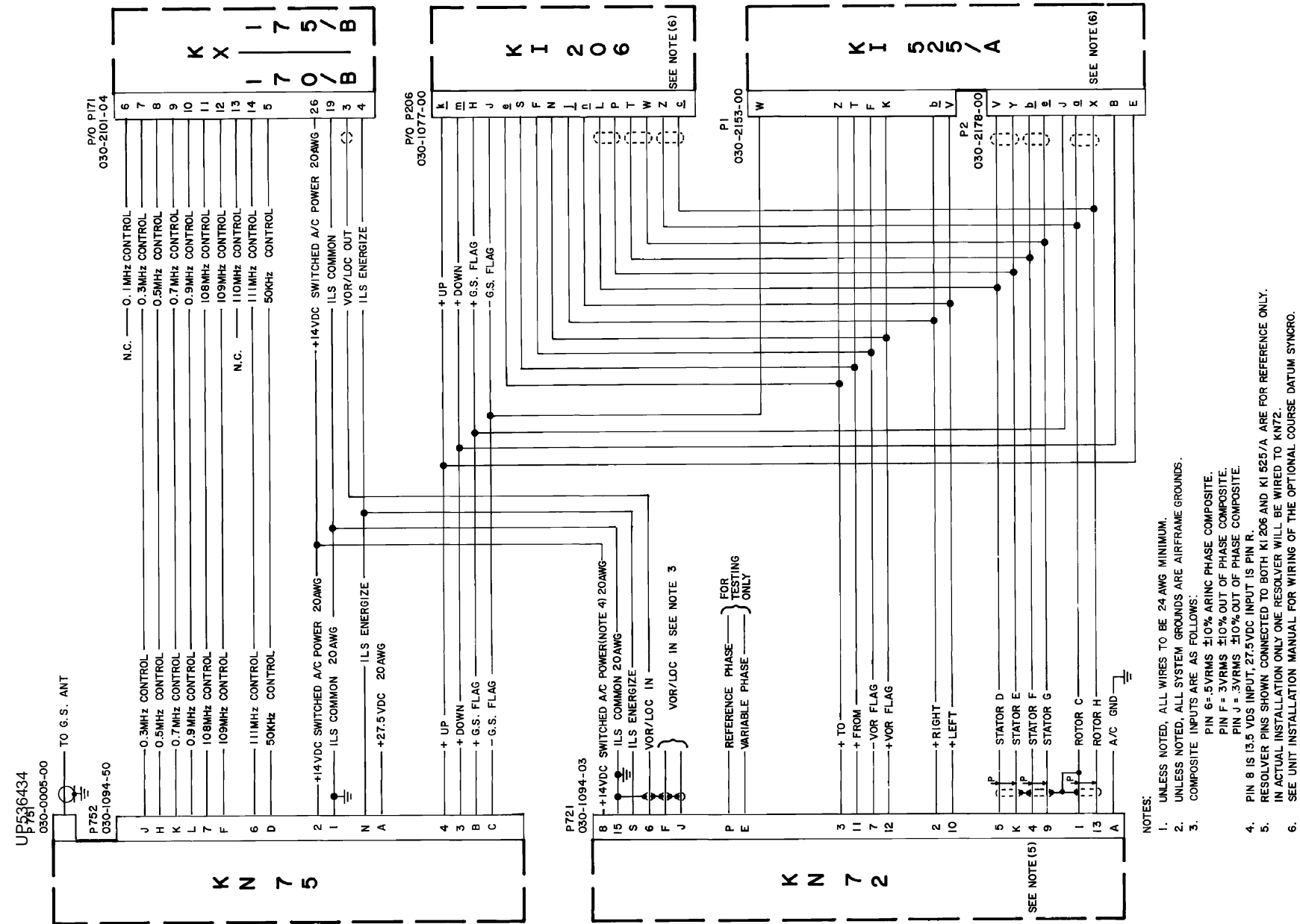
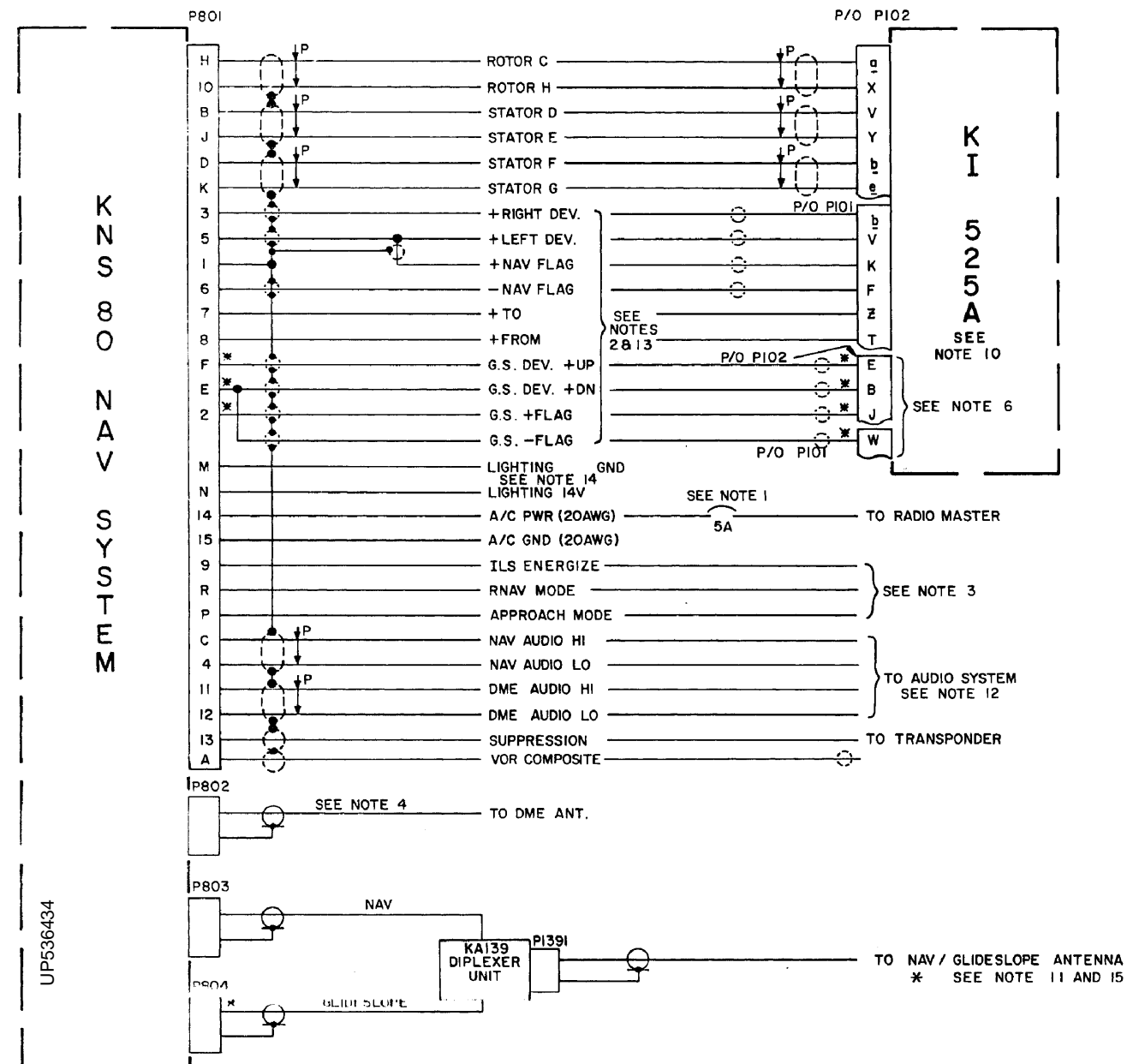

FIGURE 2-15 KN 72/KN 75/KI 525A INTERCONNECT DIAGRAM
 (Dwg. No. 155-01340-0000, R-1)

UP536434



- NOTES:
1. KNS 80 WILL ACCEPT EITHER 13.75VDC OR 27.5VDC.
 2. EXTERNAL LOADS: (MAXIMUM-NO EXTERNAL DUMMY LOADS REQUIRED.)
 NAV DEV = FIVE 1000 OHM LOADS
 NAV FLAG = THREE 1000 OHM LOADS
 TO/FROM = THREE 200 OHM LOADS
 G.S. DEV. = FIVE 1000 OHM LOADS
 G.S. FLAG = THREE 1000 OHM LOADS
 3. ILS, RNAV AND APPROACH ANNUNCIATORS:
 ACTIVE STATE: 0.8V MAX., AT 100ma MAX.
 OFF STATE: HIGH IMPEDANCE, 33V MAX.
 4. RG58/U SHOULD BE USED TO CONNECT THE ANTENNA TO P802 UP TO A MAXIMUM LENGTH OF 10 FEET. FOR CABLE RUNS EXCEEDING 10 FEET, RG142B/U CABLE SHOULD BE USED (KPN 024-0002-00).
 5. SHIELDED CABLES USED ON P803, P804 OR P807 SHALL BE RG58/U.
 6. * -CONNECTION NOT REQUIRED FOR 066-4008-01.
 7. UNLESS NOTED, ALL WIRES SHALL BE 24AWG.
 8. SINCE THE KNS 80 METER OUTPUTS ARE INTERNALLY REFERENCED TO SPECIFIC VOLTAGES, CARE MUST BE TAKEN TO PREVENT LOW IMPEDANCE PATHS FROM THE METER TERMINALS TO GROUND OR OTHER VOLTAGES.
 9. SHIELDED TWISTED PAIRS ARE HARBOUR 2XE-2634-SV OR EQUIVALENT.
 10. FOR COMPLETE LISTING OF ALL KI 525A PIN FUNCTIONS SEE KPN 006-0111-00.
 11. IF A KA139 IS NOT USED, CONNECT THE NAV ANTENNA DIRECTLY TO P803 AND THE GLIDESLOPE ANTENNA DIRECTLY TO P804.
 12. DME AUDIO IS ADJUSTABLE THROUGH TOP COVER FOR DESIRED LEVEL.
 13. AUTOPILOT OUTPUTS ARE CONNECTED IN PARALLEL WITH DEVIATION OUTPUTS AND WILL BE REFERENCED TO 4.5VDC.
 14. FOR 27.5V LIGHTING, CONNECT 27.5V DIMMER TO PIN M AND PIN N IS N/C.
 15. THE KA139 DIPLEXER SHOULD BE CONNECTED DIRECTLY TO THE NAV ANTENNA. DO NOT CONNECT THE KA139 TO THE OUTPUT OF ANOTHER NAV SPLITTER. SOME NAV SPLITTERS WHICH ARE INTENDED TO DRIVE TWO VOR/LOC NAV RECEIVERS HAVE A SIGNIFICANT AMOUNT OF INSERTION LOSS WHEN USED TO DRIVE A GLIDESLOPE RECEIVER. IF A NAV ANTENNA IS USED IN COMMON WITH TWO VOR/LOC NAV RECEIVERS THE KA139 IS NOT RECOMMENDED.

FIGURE 2-16 KNS 80 - KI 525A INTERCONNECT DIAGRAM
 (Dwg. No. 155-01316-0000, R-7)

UP536434

WARNING

IT HAS BEEN DETERMINED THAT THE KCS 55/
KCS 55A PICTORIAL NAVIGATION SYSTEM AND
ITS ASSOCIATED KA 52 AND/OR KA 57 AUTOPI-
LOT ADAPTORS ARE NOT FULLY COMPATIBLE
WITH THE PIPER ALTIMATIC II AUTOPILOT.

HONEYWELL SUGGESTS THAT NO ATTEMPT
BE MADE TO INTERFACE THE KCS 55/55A SYS-
TEM WITH THE ALTIMATIC II OR ANY OTHER "RF
SENSING DESIGN" AUTOPILOT SYSTEM.

BENDIX/KING

KCS 55/55A

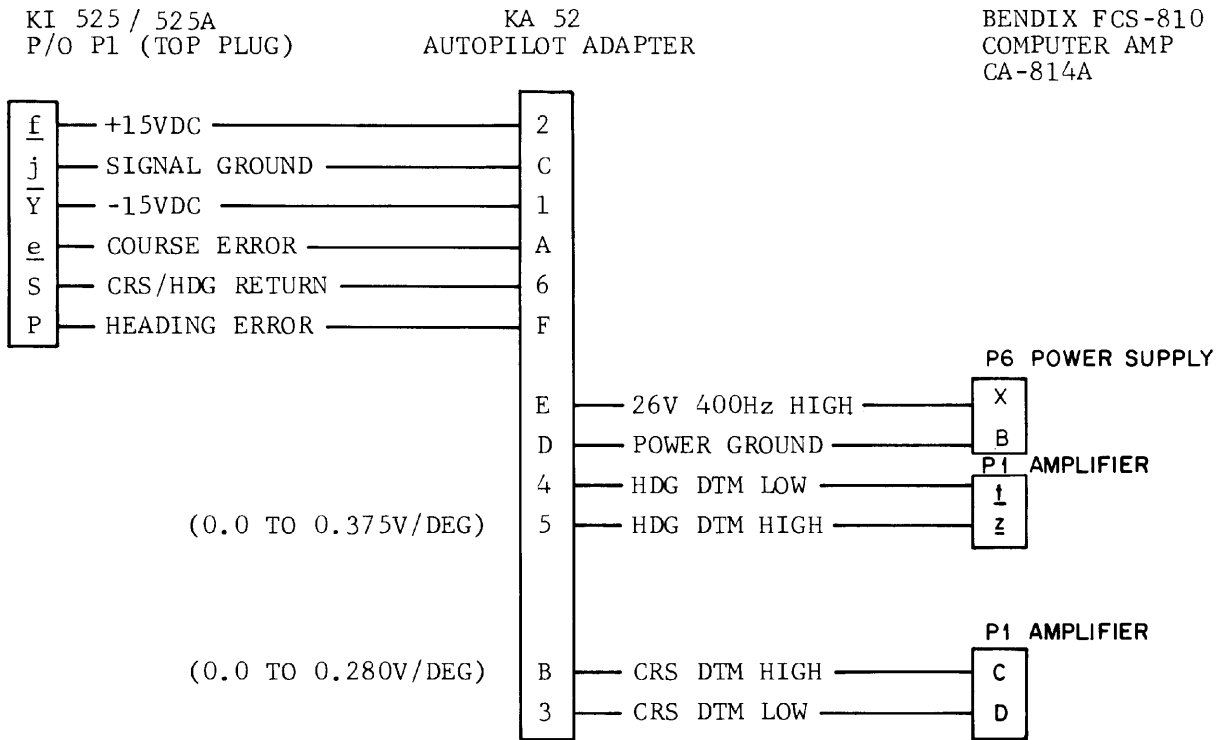

NOTES ;

1. UNLESS NOTED, ALL WIRES TO BE #24AWG MINIMUM.
2. IN THIS INSTALLATION, IT SHOULD BE NOTED THAT THE HEADING ERROR AND COURSE DATUM ERROR SIGNALS ARE NOT CONNECTED TO EACH OTHER IN THE BENDIX FCS-810.
3. THE COMPUTER AMPLIFIER CA 814A REQUIRES MOD 1.

FIGURE 2-17 KCS 55/55A/BENDIX FCS-810 AUTOPILOT INTERFACE INTERCONNECT

BENDIX/KING

KCS 55/55A

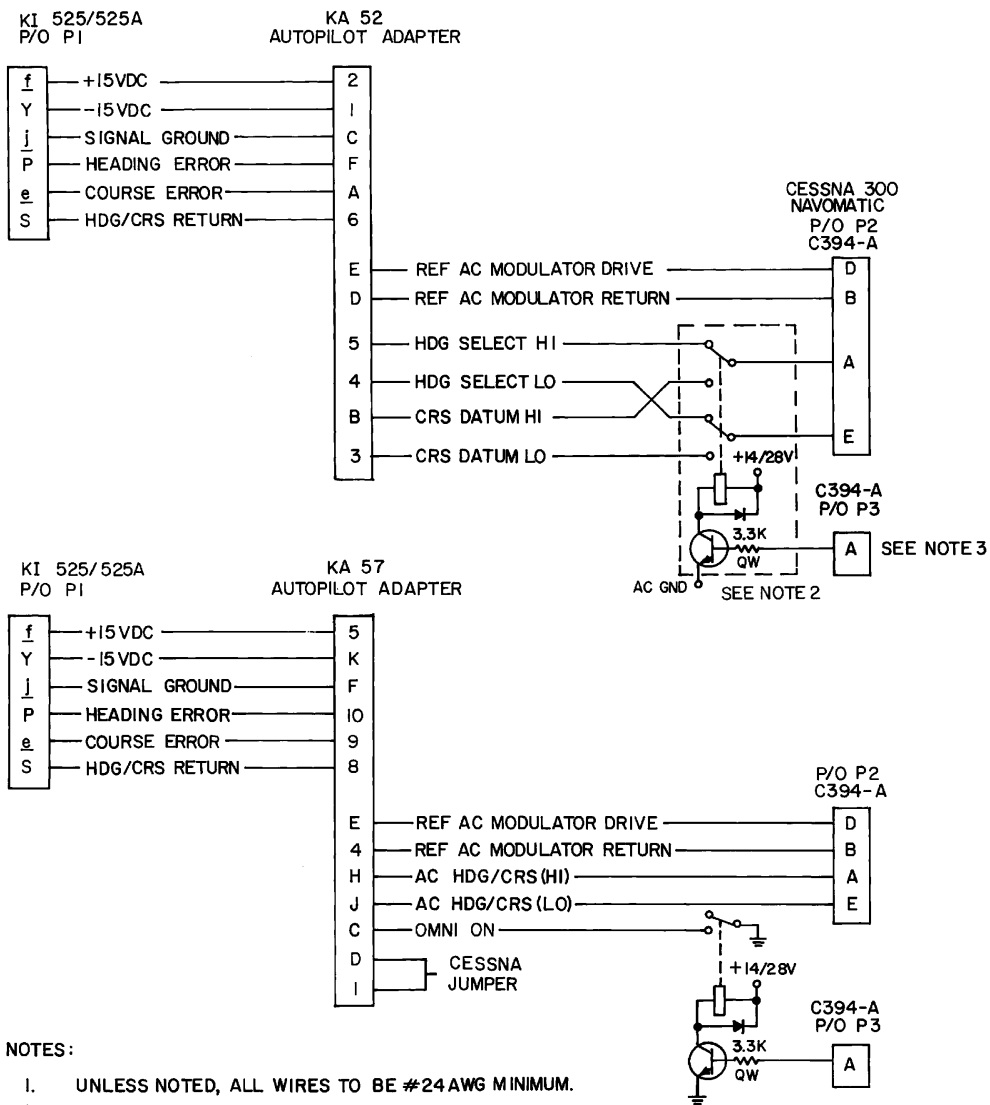
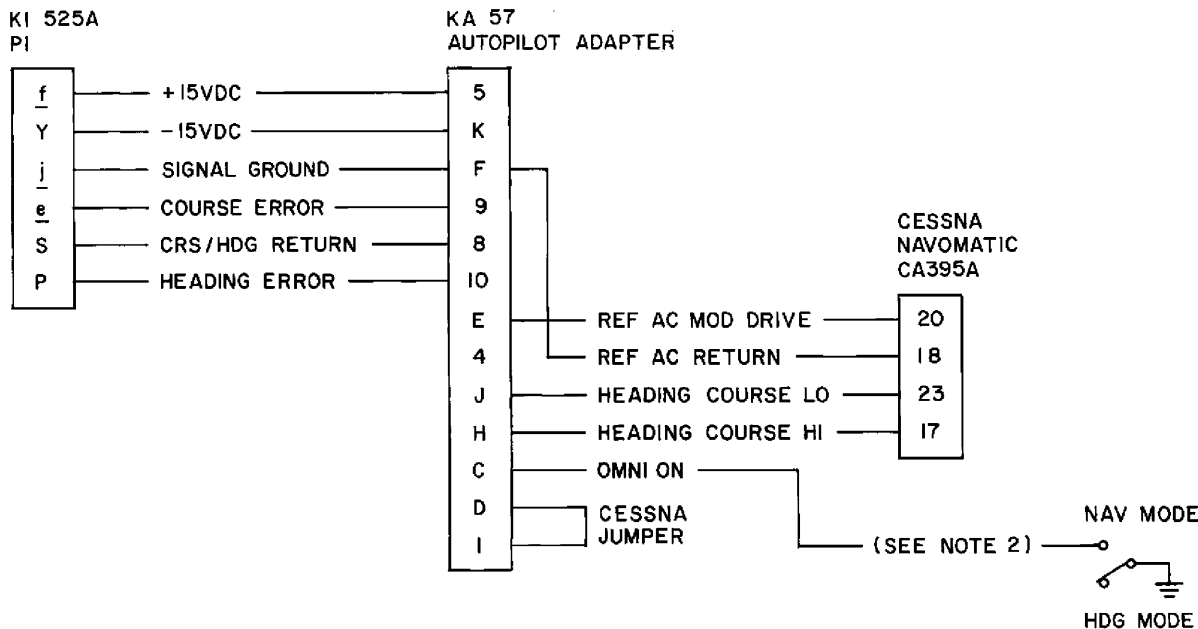

FIGURE 2-18 KCS 55/55A/CESSNA 300 NAVOMATIC INTERFACE INTERCONNECT (Dwg. No. 155-01190-0000, R-2)



NOTES:

1. KA 57 MUST BE ABOVE SERIAL NUMBER 2050 AND MUST BE ALIGNED PER THE INSTALLATION MANUAL.
2. THE OMNI ON OR NAV ENABLE LINE TO THE KA 57 MUST BE CONNECTED SO THAT WHEN NAV IS SELECTED PIN C OF THE KA 57 IS GROUNDED. WHEN THE AUTOPILOT IS IN THE HEADING MODE, PIN C OF THE KA 57 IS OPEN. A PANEL MOUNTED SWITCH NEAR THE AUTOPILOT MODE CONTROLLER IS RECOMMENDED.
3. THE TRACER OSCILLATOR, I105 IN THE KA 57, MUST BE DISABLED BY REMOVING CJ101. IN EARLIER KA 57'S WITHOUT CJ101, REMOVE C110.
4. THE KA 57 (KCS 55A SYSTEM) WILL INTERFACE WITH CA 395A COMPUTER AMPLIFIERS THAT ACCEPT ONLY AC INPUTS [P/N 42660-1 (X) (X) (X)]. THE KA 57 WILL NOT INTERFACE WITH P/N 42660-2 (X) (X) (X) COMPUTER AMPLIFIERS.
5. BECAUSE OF THE REQUIREMENTS OF THE CESSNA AUTOPILOT AND THE NORMAL OPERATING CHARACTERISTICS OF THE KA 57 AUTOPILOT ADAPTER, THE KA 57 MUST BE MODIFIED SO THAT IT WILL WORK SATISFACTORILY WITH THIS AUTOPILOT. THE MODIFICATION REQUIRED IS CONTAINED IN SERVICE BULLETIN KA 57-3 (P/N 600-01200-00XX). THIS MODIFICATION REMOVES T102, THE REFERENCE AC INPUT TRANSFORMER, AND REPLACES IT WITH A CIRCUIT JUMPER SO THAT THE AUTOPILOT REFERENCE AC WILL BE APPLIED DIRECTLY TO THE KA 57 SWITCHING CIRCUITS. THIS WILL MINIMIZE THE LOAD REPRESENTED BY THE KA 57 AND ENSURE ITS PROPER OPERATION WITH A RELATIVELY LOW REFERENCE EXCITATION VOLTAGE.
 IN ORDER TO ENSURE THAT THE MODIFIED KA 57 IS PROPERLY INSTALLED TO PROVIDE THE PROPER HEADING SELECT/NAV COURSE DATUM SWITCHING OPERATION WITH THE EXTERNAL SWITCH, THE INTERCONNECT MUST BE WIRED IN ACCORDANCE TO THIS NOTE.

FIGURE 2-19 KCS 55A/KA 57 CESSNA 300A/CA395A INTERCONNECT

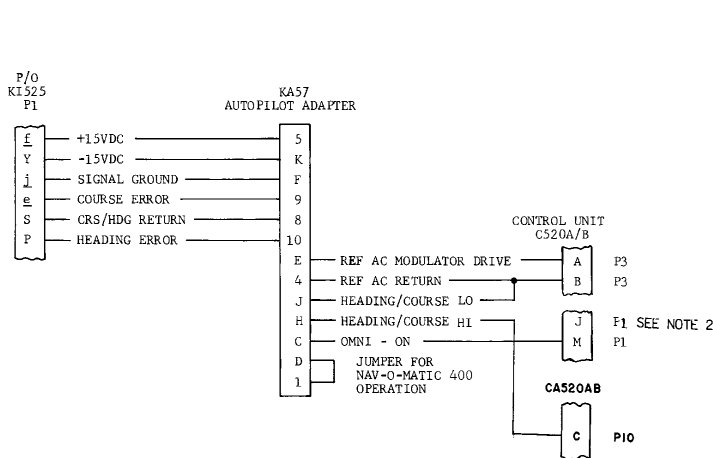

- NOTES:
1. THE TRACER OSCILLATOR IN THE KA57 MUST BE DISABLED WHEN USED WITH CESSNA AUTOPILOTS. THE TRACER OSCILLATOR IS DISABLED BY REMOVING CJ 101 IN THE KA57.
 2. THE HEADING/COURSE HI OUTPUT OF THE KA57 PIN H CONNECTS TO CA520A/B PIO PIN C. PIN J OF CONTROL UNIT PI WHICH WAS PREVIOUSLY CONNECTED TO CA520A/B PIN C (PIO) SHOULD NOT BE CONNECTED.

**FIGURE 2-20 KCS 55/55A CESSNA NAVOMATIC 400 INTERFACE INTERCONNECT
(Dwg. No. 155-01182-0000, R-3)
NOTE: THIS INTERCONNECT IS FOR 400A AUTOPILOT WITH FLIGHT DIRECTOR.**

BENDIX/KING

KCS 55/55A

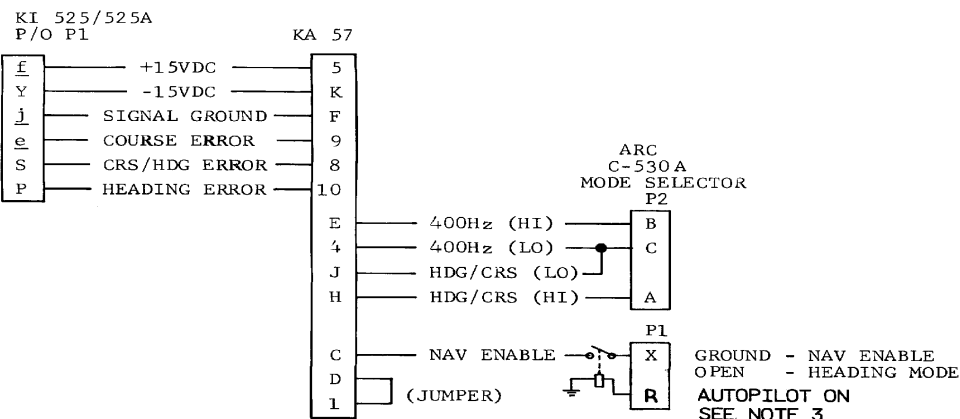
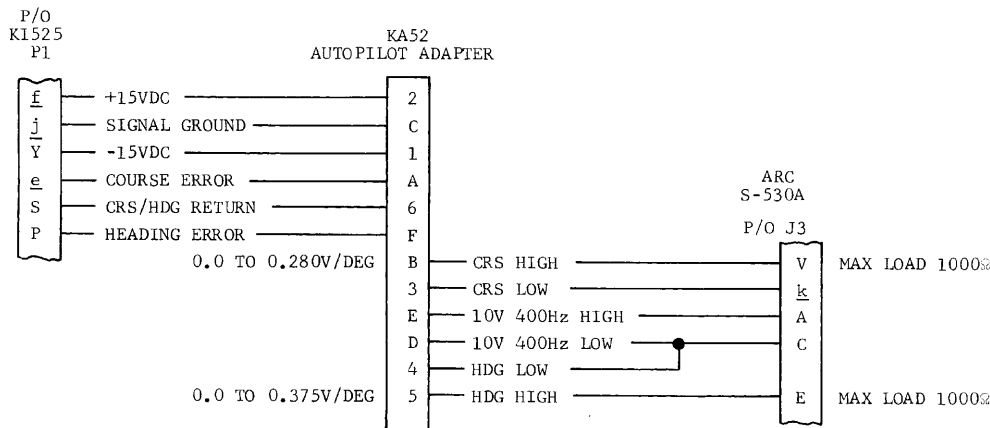

- NOTE: 1. THIS INTERCONNECT IS FOR 400A AUTOPILOT WITH NO FLIGHT DIRECTOR.
 2. THE TRACER OSCILLATOR IN THE KA57 MUST BE DISABLED WHEN THE KA57 IS USED WITH CESSNA AUTOPILOTS. DISABLE THE TRACER BY REMOVING CJ101 IN THE KA57.
 3. C530A AUTOPILOT ON SWITCH ENGAGES NAV ENABLE LINE ON KA57. RELAY MUST BE 14 VOLT OR 28 VOLT DEPENDING UPON AUTOPILOT OPERATING VOLTAGE.

FIGURE 2-21 KCS 55/55A CESSNA NAVOMATIC 400A AUTOPILOT INTERFACE INTERCONNECT
 (Dwg. Nos. 155-01180-0000, R-2; 155-01193-0000, R-1)

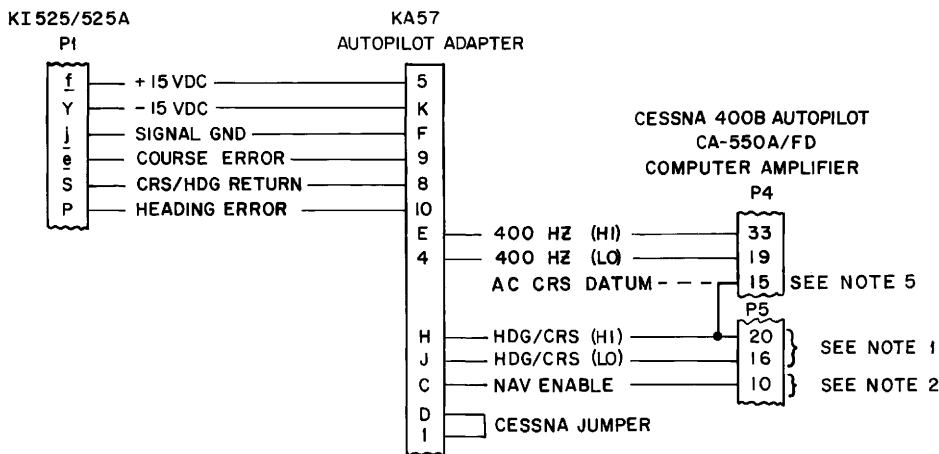

NOTES:

1. THE EXTERNAL BACKCOURSE RELAY IS NOT USED WITH THE KA57 INTERCONNECT DUE TO THE INTERNAL PHASE REVERSAL IN THE CA550A/FD COMPUTER AMPLIFIER.
2. PIN 10 GROUND IN NAV MODE - OPEN IN HEADING MODE.
3. THE TRACER OSCILLATOR IN THE KA57 MUST BE DISABLED WHEN USED WITH CESSNA AUTOPILOTS. DISABLE THE TRACER OSCILLATOR BY REMOVING CJ101 IN THE KA57.
4. FOR THE ABOVE INTERCONNECT THE CA-550A/FD MUST BE STRAPPED FOR USE WITH A VACUUM DG WITH A HEADING BUG OUTPUT. REFERENCE THE CESSNA 400B AUTOPILOT MANUAL. IF A VACUUM DG WITH HEADING BUG OUTPUT IS BEING REPLACED WITH THE KCS 55A NO AUTOPILOT WIRING CHANGES SHOULD BE REQUIRED. IF AN HSI IS BEING REPLACED WITH THE KCS 55A THE CESSNA 400B MANUAL SHOULD BE REFERENCE FOR THE CORRECT STRAPPING ON THE CA 550/FD.
5. IN A CESSNA 400B AUTOPILOT ONLY CONFIGURATION, THE KA57 HDG/CRS (HI) FROM PIN H MUST ALSO BE CONNECTED TO CA 550A/FD P4 PIN 15 TO PROVIDE AC COURSE DATUM INFORMATION WHEN THE AUTOPILOT AND KA57 ARE IN THE NAV/LOC MODE.

FIGURE 2-22 KCS 55/55A/CESSNA 400B AUTOPILOT INTERFACE INTERCONNECT (Dwg. No. 155-01254-0000, R-3)

BENDIX/KING

KCS 55/55A

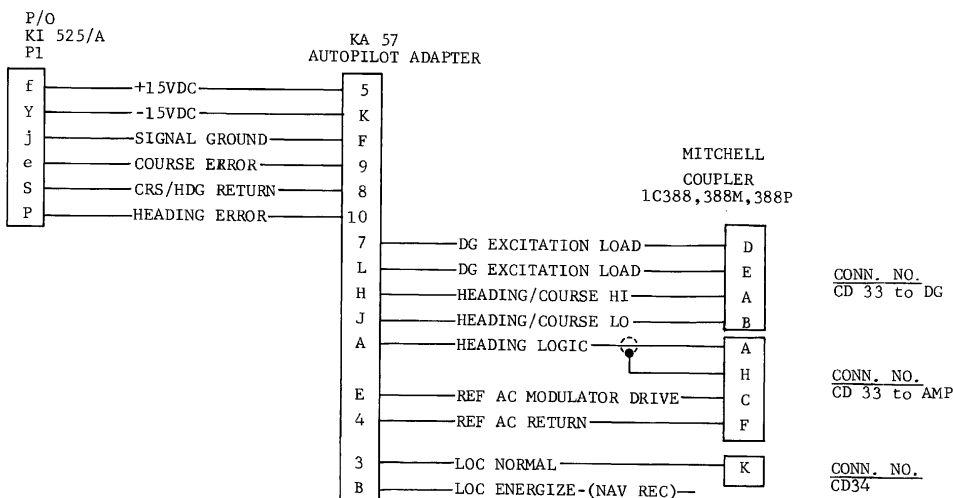

FIGURE 2-17A

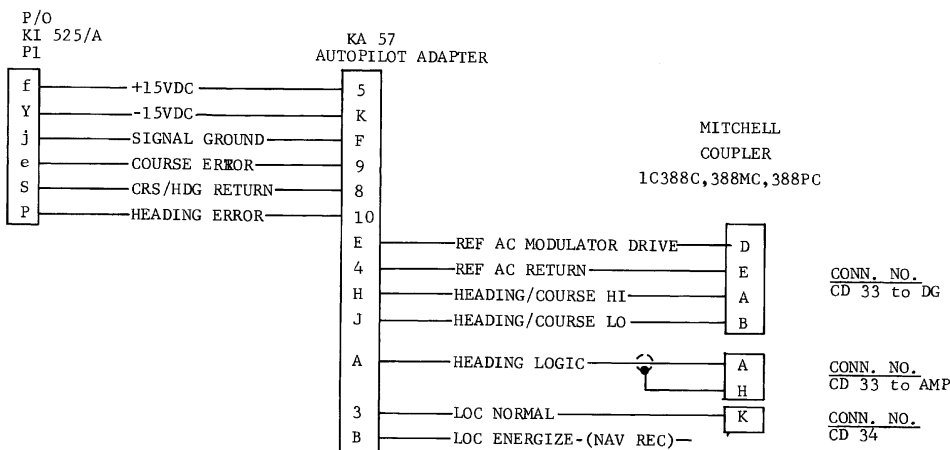

FIGURE 2-17B

NOTES;

1. WIRES ATTACHED TO CONNECTORS CD33 TO AMP AND CD34 ARE CONNECTED IN PARALLEL WITH EXISTING WIRES.

**FIGURE 2-23 KCS 55/55A MITCHELL COUPLER
 IC-388, 388C, 388M, 388MC INTERFACE INTERCONNECT
 (Dwg. No. 155-01181-0000, R-6)**

BENDIX/KING

KCS 55/55A

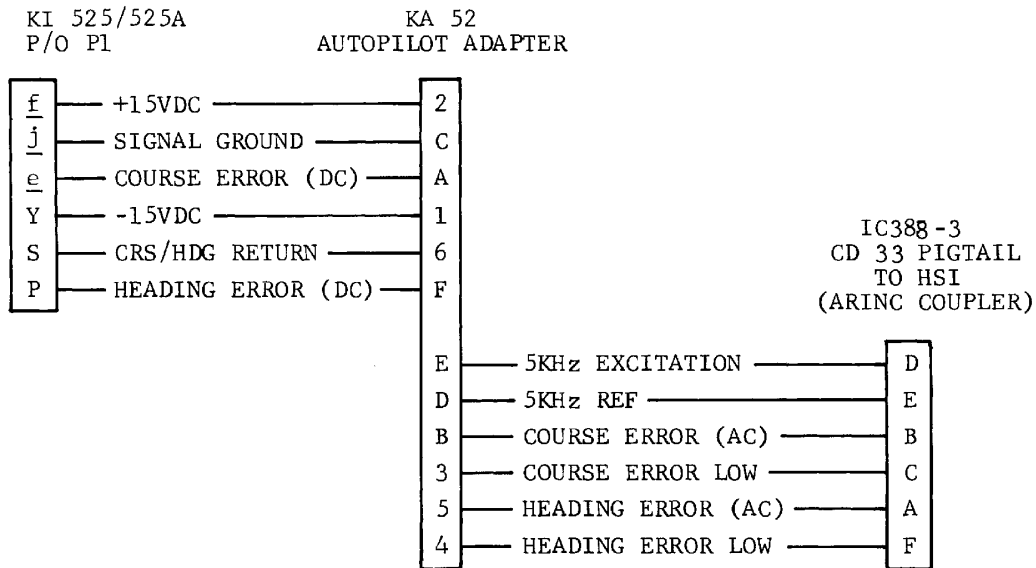

UNLESS NOTED, ALL WIRES TO BE #24AWG MINIMUM.

**FIGURE 2-24 KCS 55/55A MITCHELL III AUTOPILOT
 w/IC 388-3 COUPLER INTERFACE INTERCONNECT
 (Dwg. No. 155-01192-0000, R-0)**

UP536434

BENDIX/KING

KCS 55/55A

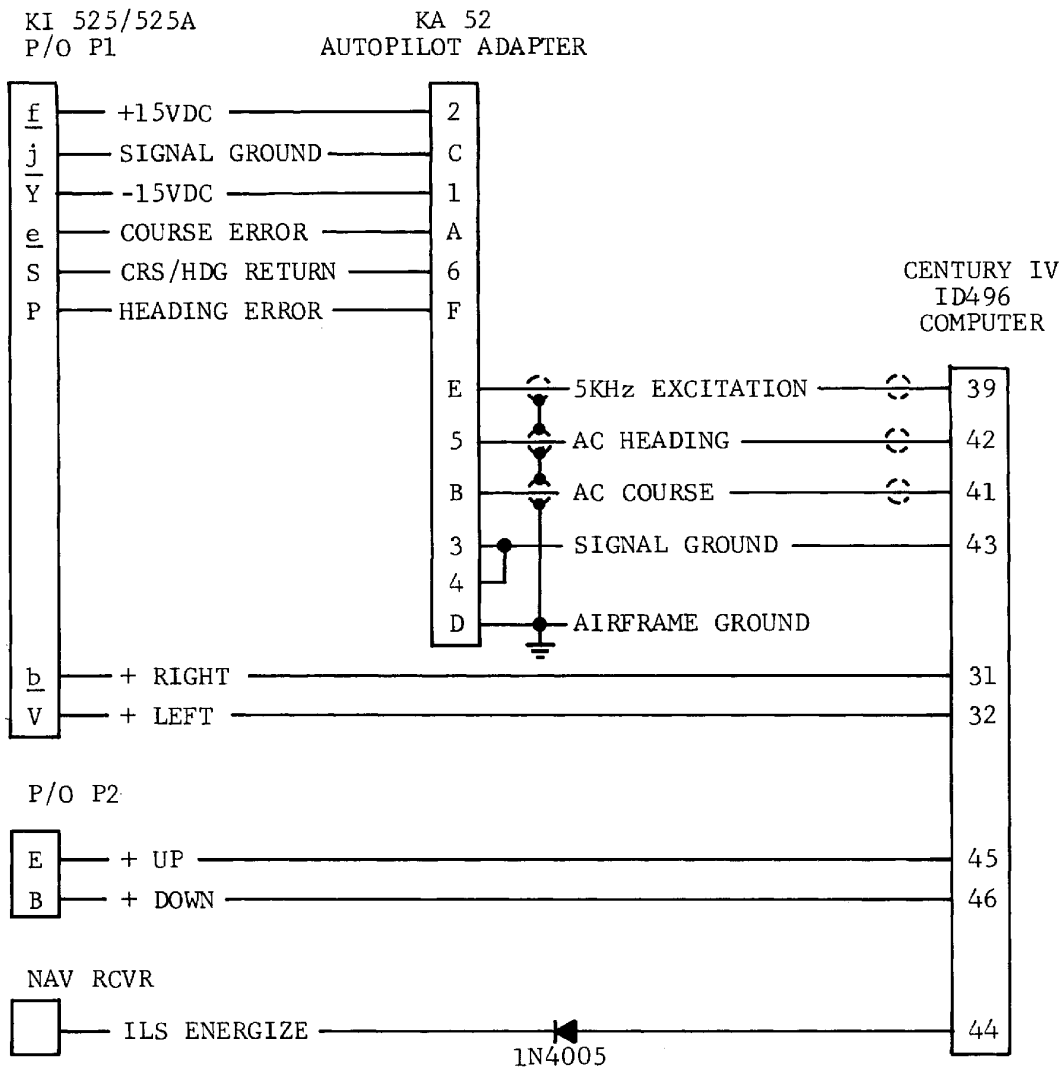

NOTE: ID496 COMPUTER MUST BE ARINC TYPE ID496-X1XX2.

FIGURE 2-25 KCS 55/55A MITCHELL CENTURY IV AUTOPILOT INTERFACE INTERCONNECT (Dwg. No. 155-01191-0000, R-1)

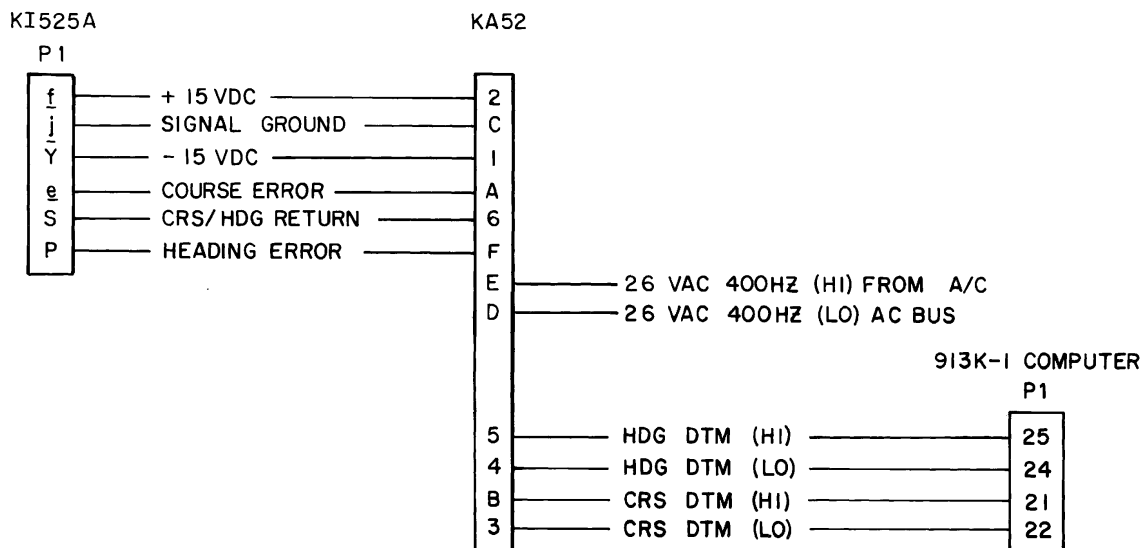

NOTE: IN THIS INSTALLATION, ALIGN THE KA52 PER THE KA57 PROCEDURE IN THE KCS 55/KCS55A SYSTEM INSTALLATION MANUAL.

**FIGURE 2-26 KCS 55/55A - AP106/AP107/913K-1 COMPUTER AMPLIFIER
AUTOPILOT INTERFACE INTERCONNECT
(Dwg. No. 155-01255-0000, R-0)**

BENDIX/KING

KCS 55/55A

THIS PAGE IS RESERVED

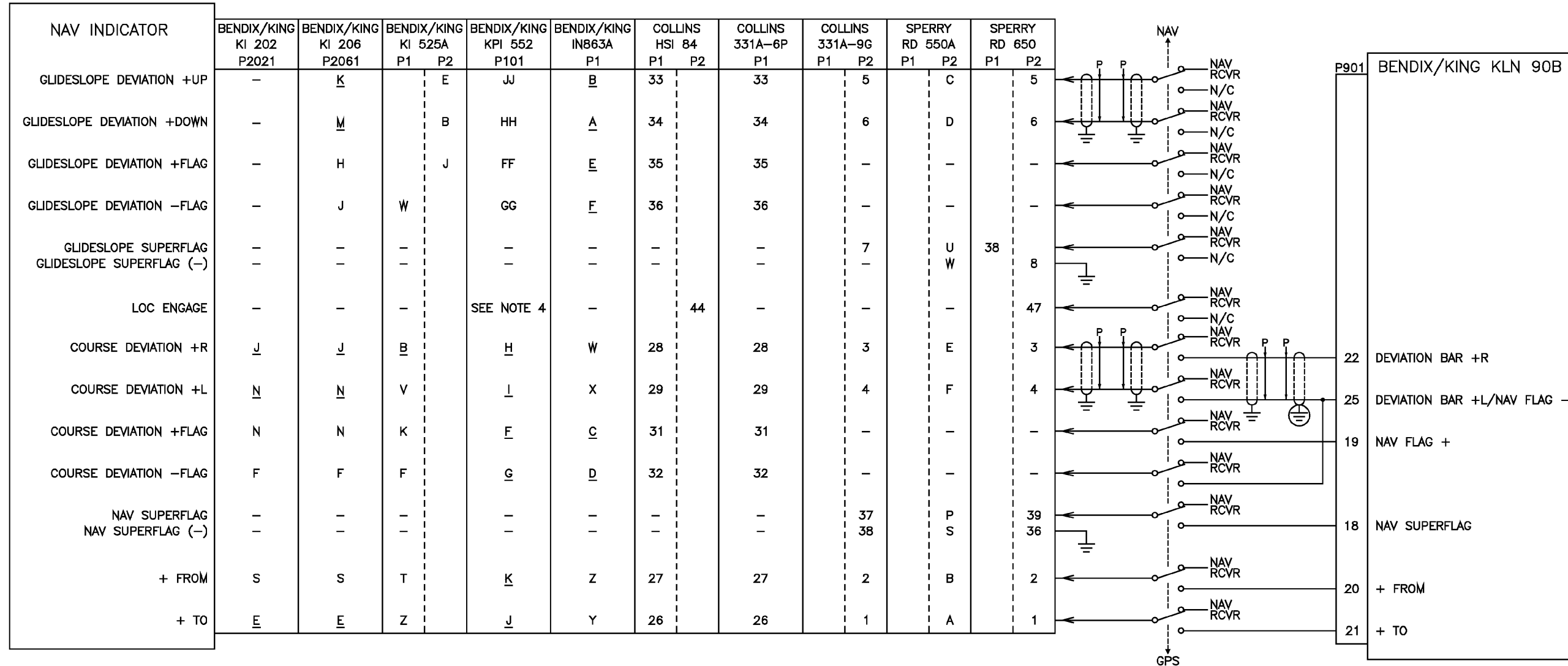

NOTES:

1. LOWERCASE LETTER CONNECTORS PIN DESIGNATORS ARE SHOWN AS UNDERLINED UPPERCASE LETTERS.
2. ALL WIRES ARE 24 AWG MINIMUM UNLESS OTHERWISE NOTED.
3. NOT ALL RELAYS ARE NEEDED FOR ALL INSTALLATIONS. A RELAY IS NOT REQUIRED IF AN INDICATOR PIN IS NOT SHOWN FOR THAT RELAY.
4. A RELAY IS NOT REQUIRED FOR THE LOC ENGAGE CONNECTION TO THIS INDICATOR AS THIS PIN DOES NOT HAVE A COURSE DEVIATION FUNCTION; IT IS USED TO PARK THE RMI NEEDLE.
5. CONNECT THESE SHIELD GROUNDS TO UNIT BACKSHELL GROUND.
6. CONNECT THESE SHIELD GROUNDS TO AIRCRAFT CHASSIS WITH AS SHORT A CONDUCTOR AS PRACTICAL.

FIGURE 2-27 KLN 90B - KI 525A INTERCONNECT DIAGRAM
(Dwg. No. 155-06021-0000, R-AB, Sheet 1 of 2)

UP536434

UP536434

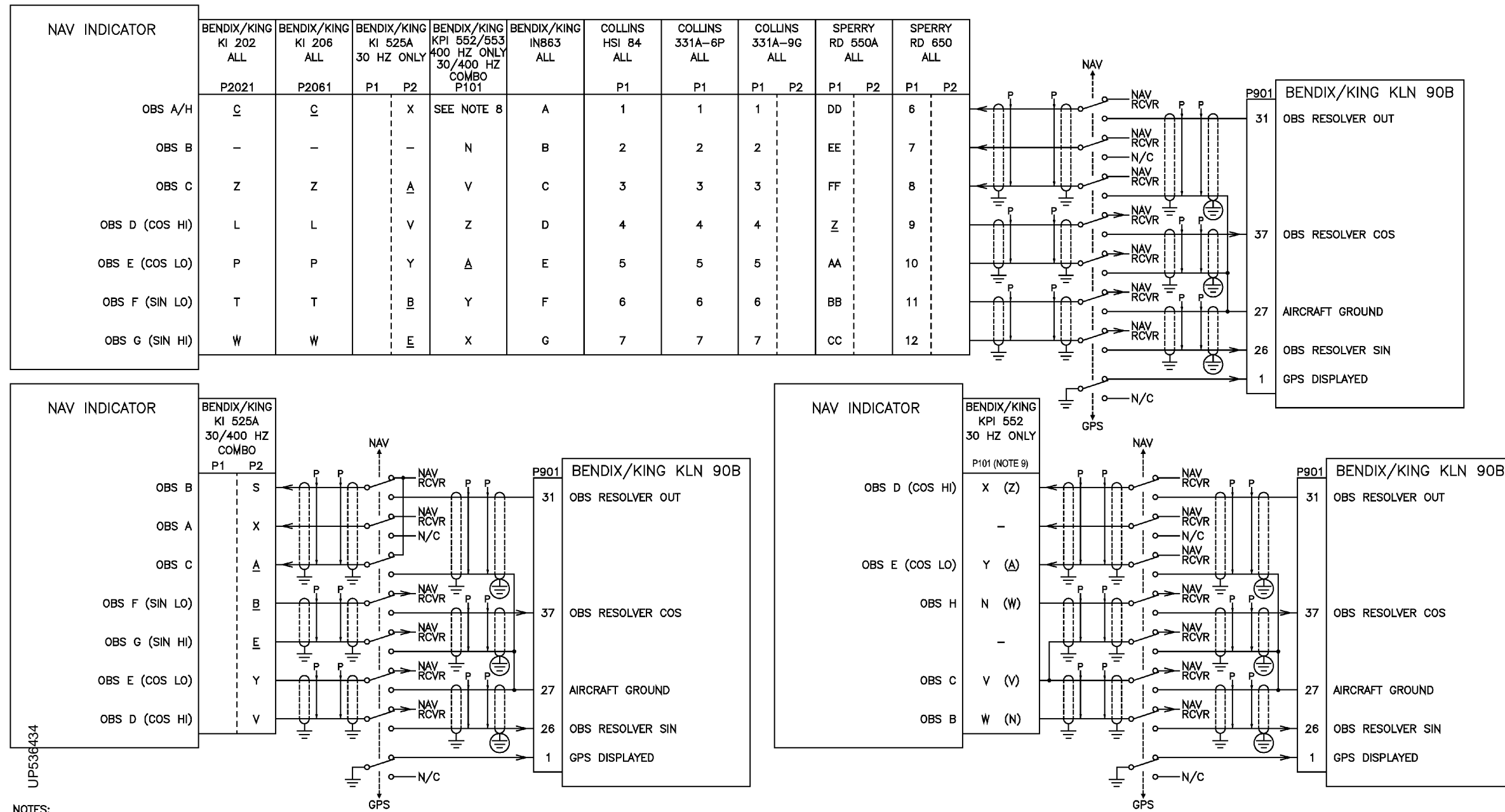

NOTES:

1. LOWERCASE LETTER CONNECTORS PIN DESIGNATORS ARE SHOWN AS UNDERLINED UPPERCASE LETTERS.
2. ALL WIRES ARE 24 AWG MINIMUM UNLESS OTHERWISE NOTED.
3. NOT ALL RELAYS ARE NEEDED FOR ALL INSTALLATIONS. A RELAY IS NOT REQUIRED IF AN INDICATOR PIN IS NOT SHOWN FOR THAT RELAY.
4. WHEN THE KLN 90B IS USED WITH A KA 90 HSI ADAPTER, THE KA 90 OBS CONNECTIONS ARE USED AND THE KLN 90B OBS CONNECTIONS BECOME NO CONNECTION. WHEN A KA 90 IS USED, THE FOLLOWING KLN 90B PINS BECOME NO CONNECTION: OBS RESOLVER OUT, P901-31; OBS RESOLVER COS, P901-37; OBS RESOLVER SIN, P901-26; GPS DISPLAYED, P901-1.
5. THE KX 165 NAV/COM AND THE KNS 80 AND KNS 81 RNAV'S WILL FLAG SOME OF THEIR OUTPUTS WHEN THEY ARE NOT CONNECTED TO AN OBS RESOLVER. IF THE KLN 90B SHARES THE NAV INDICATOR WITH ONE OF THESE UNITS THROUGH THE NAV/GPS RELAY, REFER TO SHEET 6 FOR INFORMATION ON HOW TO LOAD THE NAV RECEIVER'S OBS LINES FOR PROPER OPERATION OF THESE NAV RECEIVERS.
6. CONNECT THESE SHIELD GROUNDS TO UNIT BACKSHELL GROUND.
7. CONNECT THESE SHIELD GROUNDS TO AIRCRAFT CHASSIS WITH AS SHORT A CONDUCTOR AS PRACTICAL.
8. FOR 400 HZ. CONNECT TO PIN "A". FOR 30/400 HZ. CONNECT TO PIN "W". THIS APPLIES TO ALL KPI 552/552B AND KPI 553/A/B WITH 30/400 RESOLVERS.
9. IF OBS POINTER ON A KPI 552 IS 90° OUT, USE THE PINS INDICATED IN PARENTHESIS.

FIGURE 2-27 KLN 90B - KI 525A INTERCONNECT DIAGRAM
(Dwg. No. 155-06021-0000, R-AB, Sheet 2 of 2)

UP536434

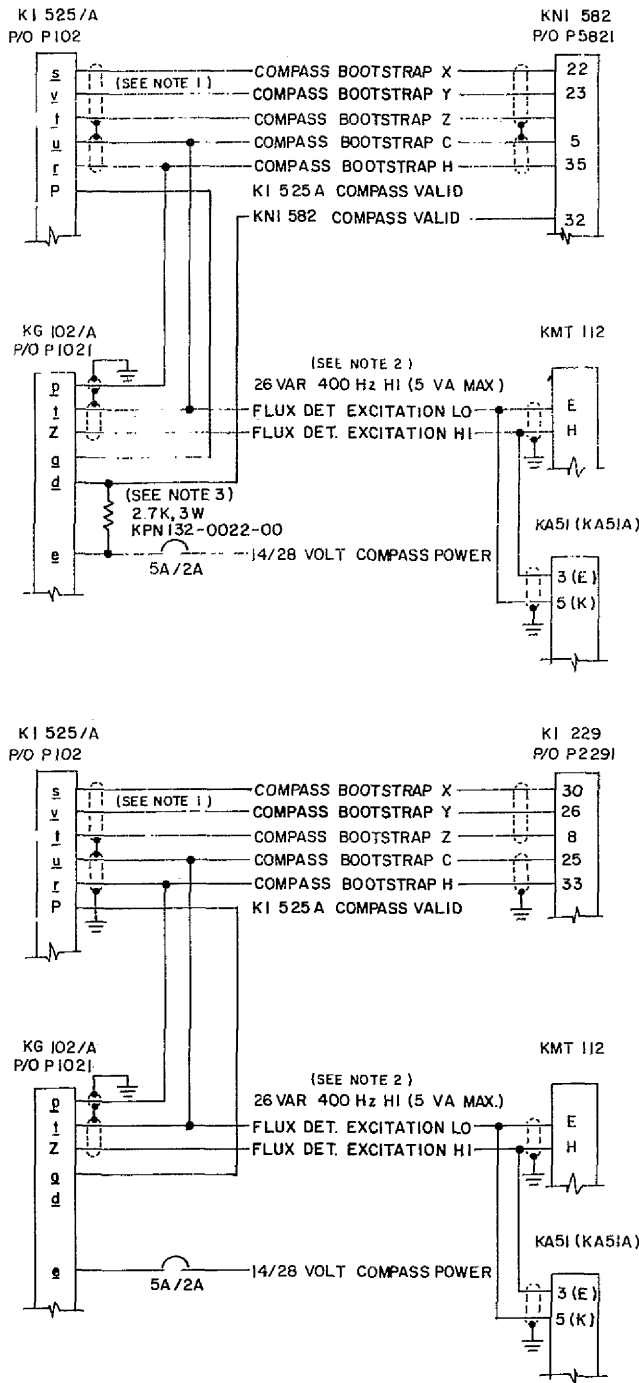

Notes:

- Using the KG 102/102A as a 26V, 400 Hz. supply, the compass X, Y, and Z input of the K1 229 or KNI 582 must be the only load on the compass bootstrap output.
- The KG 102/102A has only 5 VA of available 26V, 400 Hz. power at pin p and t and should not be overloaded.
- The 2.7K resistor provides a pull up for the compass valid to the KNI 582. Pin D pulls the compass valid low in an invalid condition.

FIGURE 2-28
KG 102/102A 400 Hz. Supply Interconnection Diagrams

BENDIX/KING

KCS 55/55A

THIS PAGE IS RESERVED

SECTION III OPERATION

3.1 DISPLAY DESCRIPTION

This section contains information pertaining to controls and indicators, operating procedures, and emergency operation of the KCS 55/55A Pictorial Navigation System. Refer to Figures 3-1, 3-2 and 3-3 for additional information.

3.1.1 KI 525/525A INDICATOR AND CONTROLS

INDICATOR AND CONTROLS	FUNCTION
Compass Card:	This rotating card displays gyro stabilized magnetic compass in formation beneath the lubber line.
Heading Select Knob:	Positions the heading select marker relative to the compass card.
Symbolic Aircraft:	Represents the relationship of the aircraft with respect to the display.
Reciprocal Course Pointer:	Indicates the reciprocal of the selected course.
Course Select Knob:	Positions the selected course pointer with respect to the compass card.
Lateral Deviation Bar:	Represents VOR radial or LOC course. When referenced to the symbolic aircraft the position of the deviation bar is the same as the position of the chosen VOR radial or LOC Course to the air craft.
Glideslope Pointer:	Represents the actual aircraft deviation from the glideslope path. When unusable glideslope information is present the glideslope pointer is biased out of view. When a valid glideslope signal is received there is a 2 to 12 second delay before the pointers come into view.
Heading Select:	Indicates the selected aircraft heading.
NAV Warning Flag:	When unusable VOR/LOC information is present the warning flag is in view.
Lubber Line:	Aircraft magnetic heading is read under this line.
Heading Warning Flag: (KI 525A only)	Inadequate Power, manual slave, fast auto slave or spin motor less than 50% normal speed.
Power Flag (KI 525 only)	Inadequate Power.
Selected Course Pointer:	Indicates the selected VOR radial or LOC course.
To-From Indicator:	Indicates the direction to the VOR station along the selected radial.
Slaving Meter:	Indicates the difference between the displayed heading. Positive deflection indicates a clockwise error of the compass card.
Counterclockwise Manual Heading Drive Pushbutton:	When the system is in the free gyro mode, engagement of this pushbutton will cause the compass card rotate counterclockwise at a constant rate of 360 degrees per minute.

INDICATOR AND CONTROLS	FUNCTION
Slave/Free Gyro Pushbutton:	When depressed the system is in the slaved gyro mode. When the button is in the outer position the system is in the free gyro mode.
Clockwise Manual Heading Drive Pushbutton:	When the system is in the free gyro mode, engagement of this pushbutton will cause the compass card to rotate clockwise at a constant rate of 360 degrees per minute.

3.2 OPERATING PROCEDURES

When power is applied to the KCS 55 System the PWR flag will disappear from view if the power is normal. If the system is in the slaved gyro mode the compass card will automatically fast slave at the rate of 180 degrees per minute towards the magnetic heading. The system will remain in this fast slave mode for 120 seconds after which it will automatically revert to the normal slaving mode and slave at a constant rate of 3 degrees per minute to keep the system aligned with the earth's magnetic field. The slaving meter on the KA 51 indicates relative deviation from this alignment.

When power is applied to the KCS 55A System the HDG flag will remain in view until the following conditions are satisfied: The gyro spin motor is at least 50% of normal speed, the fast slave mode has been executed and normal system power is present. The fast slaving mode is initiated when power is applied and is switched to the slow slave mode when the slaving error is reduced to zero. The fast slave rate is 180 degree/minute. The slow slave rate is 3 degree/minute to keep the system aligned with the earth's magnetic field. The slaving meter on the KA 51A/51B indicates relative deviation from this alignment.

Set the navigation receiver to the desired VOR/LOC station and rotate the course select knob to adjust the selected course pointer to the desired course radial. When a usable navigation signal is received by the KI 525A the NAV warning flag will disappear from view.

The KI 525A lateral deviation bar represents the selected VOR/LOC course. The relationship of the deviation bar to the symbolic aircraft presents the relationship of the selected course to the aircraft.

For an ILS approach, tune the navigation receiver to the desired frequency. For LOC operation the selected course pointer should be set to the inbound localizer course. The glideslope pointer will deflect into view after a 2 to 12 second delay if a usable glideslope signal is received. The glideslope pointer indicates the relative position of the glideslope path with respect to the aircraft. For LOC operation and ILS front course approach, tune the navigation receiver to the desired frequency, set the pointer to the selected inbound localizer course, and if a usable glideslope signal is received the glideslope pointer will deflect into view. The glideslope pointer indicates the position of the glideslope path with respect to the aircraft. The position of the deviation bar with respect to the symbolic aircraft indicates the relative position of the selected course. For backcourse operation set the course pointer to the inbound localizer course. The deviation bar position relative to the symbolic aircraft then represents the position of the backcourse with respect to the aircraft.

3.3 EMERGENCY OPERATION

If the KI 525 input power warning flag appears, the compass system has experienced a power failure and the card indications are in error. Remove power from the KG 102; the lateral deviation bar and the To-From indicator will remain in operation.

If the KI 525A HDG flag appears in view after the system has been operating or will not go out of view after initial power up, one of the following conditions exists and the compass information will not be reliable:

- 1) The gyro on the KG 102A is not running above 50% of its normal speed.
- 2) The system has not rotated to the magnetic heading and switched out of fast slave on initial power up.
- 3) The power supply in the KG 102A is not functioning properly.
- 4) KG 102A (060-0015-02). Tumble detection circuit has detected gyro tumble conditions - reverting the system back into fast slave mode to correct the error. Once the system has re-acquired proper display information by matching earth's magnetic field, the system will revert back to slow slave mode, i.e. normal operation.

A continuous large deflection of the slaving meter or large discrepancies between the magnetic compass and the KI 525/525A compass card may indicate a failure in the slaving system and may not necessarily be annunciated by the HDG flag. If a slaving failure should occur the SLAVE IN button on the KA 51/51A/51B should be returned to its outer position. The system will now be in the free gyro mode. By depressing the clockwise or counterclockwise button (toggle switch on the KA 51B) on the KA 51/51A the compass dial can be repositioned to the correct heading. The KCS 55/55A will continue to function normally except the heading information will be solely derived from the KG 102/102A Gyro, there will be no magnetic correction from the KMT 112.

If the KI 525/525A NAV flag appears the navigation equipment is off, improperly tuned, or malfunctioning. If possible switch to another navigation receiver. The compass card on the KI 525/525A will continue to display the aircraft heading.

If the KI 525/525A glideslope pointer remains out of view during ILS operation the glideslope transmitter or the aircraft glideslope receiver is malfunctioning. If possible switch to another glideslope receiver. The localizer and heading displays will continue to function normally.

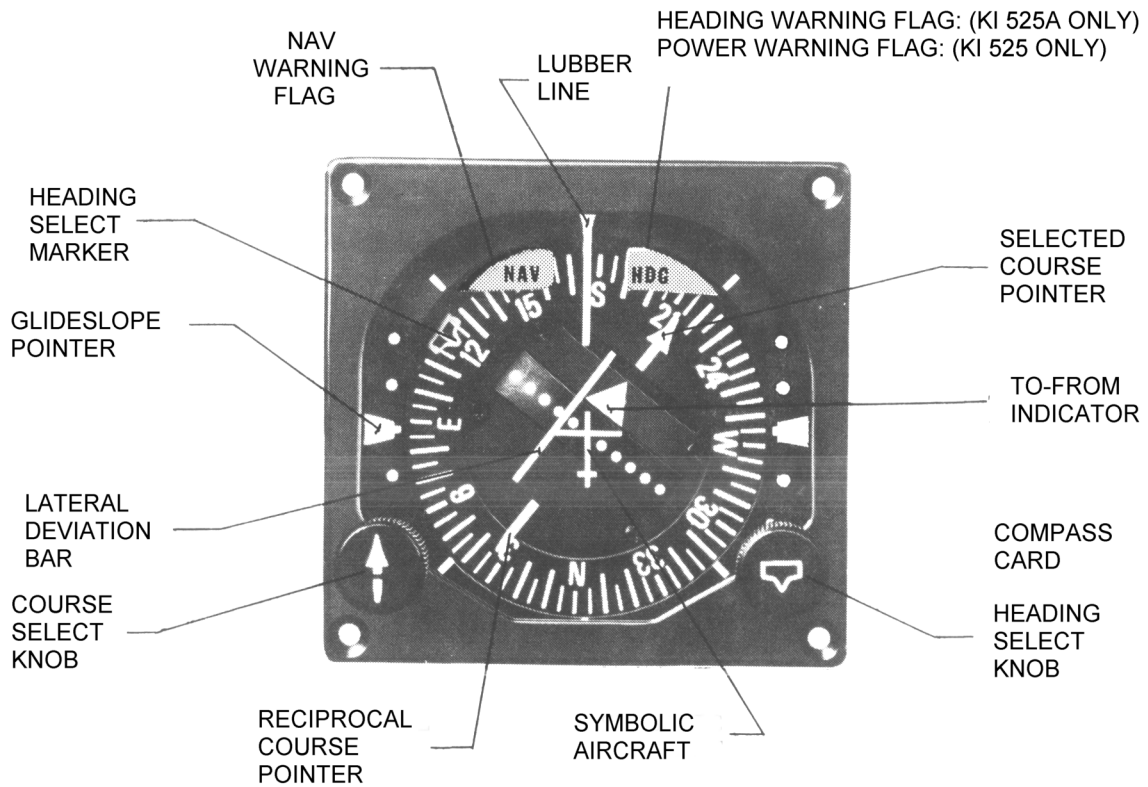

FIGURE 3-1
KI 525/525A INDICATOR AND CONTROLS

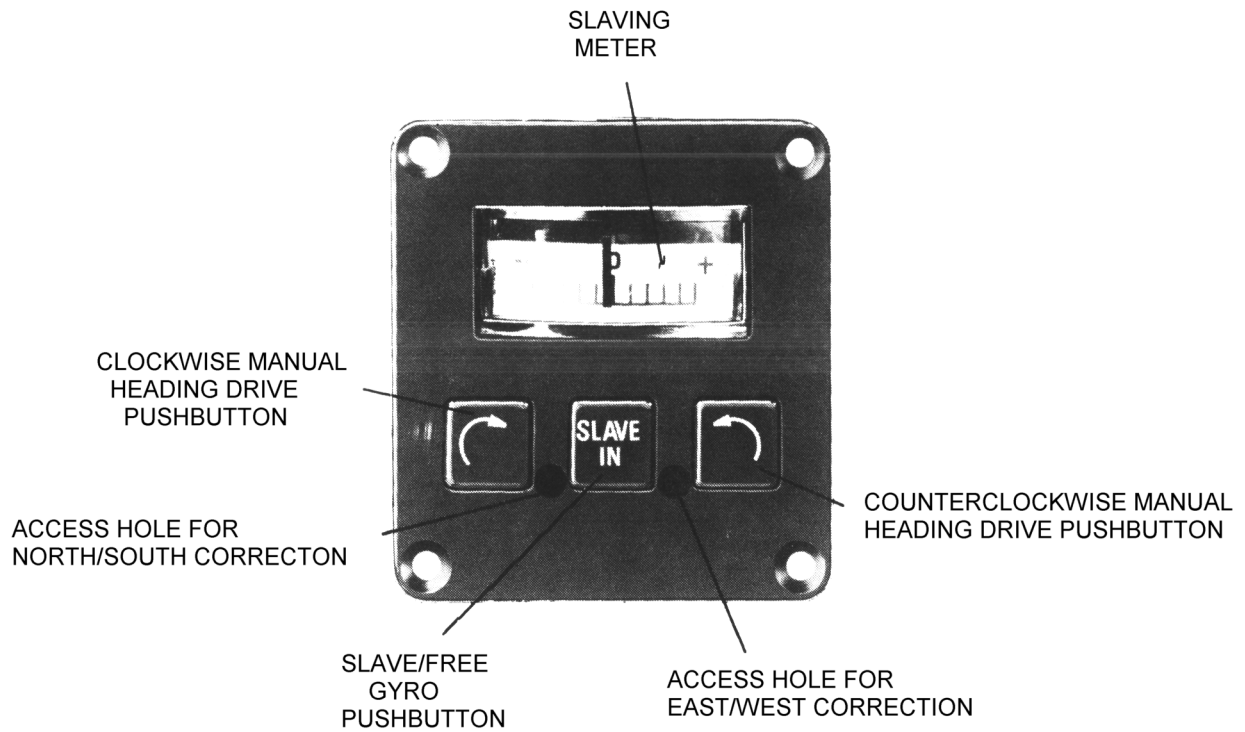
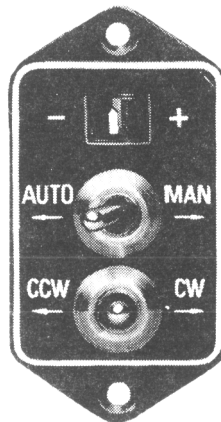

FIGURE 3-2
KA 51/51A SLAVING ACCESSORY AND CONTROLS

BENDIX/KING

KCS 55/55A



**FIGURE 3-3
KA 51B SLAVING ACCESSORY AND CONTROLS**